



GV3

LINEAR GUIDANCE AND TRANSMISSION SYSTEM

This catalogue interacts with the HepcoMotion website



Additional information can be viewed within the online GV3 Technical Guide when you click this icon:



To assist browsing this catalogue online, clicking wherever you see blue hypertext, page number, or a product icon in the page margins, will take you directly to the section required:

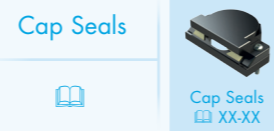

Where other HepcoMotion product ranges are referred to, clicking on the title will take you to the catalogue in question:

HDS2 Heavy Duty Linear Guide

The full contents of the GV3 Technical Guide can be viewed or downloaded by clicking this icon:



New additions and catalogue amendments can also be found here.

GV3 linear guidance and transmission system

Smooth – Fast – Accurate – Quiet
Durable – Simple – Versatile – Economic

An unrivalled linear motion system, designed to serve a diverse range of automation and linear applications.



Contents

Refer also to Quick Reference icons in page margins

System Composition	2 - 9	Application Examples	10 - 17
Full Size Illustrations	18 - 20	System Selector	21
Standard & Slimline Carriages	22 - 25	Removable Carriages	8
Carriage Locking Device	9	End Stops & Shock Absorbers	9
Slides	26 - 31	Slide Beams	32 - 33
Standard & Slimline Bearings	34 - 37	Vacuum & Extreme Temperature	7
Floating Bearings	7	Twin Taper Roller Bearing	7
Lubrication Devices	38 - 40	Bleed Lubrication	41
Flange Clamps	8	Side Access Adjustment	8
Flat Tracks	42	Track Rollers	43 - 45
Racks	46	Pinions	47
Belt Driven Carriages	6	Rack Driven Carriages	48
Gearboxes, Drive Flanges & AC Geared Motors	49	GV3-MCS Connectivity	7
Load/Life Calculations	50 - 52	Technical Specifications	53
System Assembly & Adjustment		Drive System Recommendations	
Drive Calculations for Rack Driven Carriages		Load/Life Calculation Examples	
Deflection of Self-Supporting Slides		'Mix & Match' Component Compatibility	
Data & Dimensions for Assembled Systems		Component Mass	



Linear Motion System with Standard Bearings

INDIVIDUAL COMPONENTS,
OR FULLY-ASSEMBLED
AND ADJUSTED SYSTEMS,
READY TO INSTALL

ALL SLIDES (COMMON FEATURES)  **26-31**

- One piece construction for assured parallelism and rigidity.
- Manufactured from high quality bearing steel.
- Deep hardened V faces for maximum wear resistance.
- Soft centre section allows customising.
- Any length supplied up to 4 metres.
- Unlimited length achieved by butting.
- Attractive, corrosion inhibiting black finish on unground faces.
- Common 70° 'V' allows many Bearing/Slide combinations.

BLIND HOLE BEARING  **34-35**

- For mounting into thick plates or where access to opposite side is restricted.
- Eccentric version adjusted from operating side for ease of access.
- Concentric version (shown on opposite side of the Slide) has threaded axle and locates into tapped hole in the mounting surface.

SINGLE EDGE SPACER SLIDE  **28-29**

- Mounts directly to a flat surface. No spacer required.
- Can be spaced apart for high moment load capacity.
- Back face provides mounting register, or running surface for Track Roller.
- Keyway and datum edges provide means of location and alignment.
- Rack cut option provides means of driving.
- Counterbored holes, tapped holes or un-drilled options available.

DOWEL PIN
 **27 & 29**

- Easy method of location and alignment.

DOUBLE EDGE FLAT SLIDE
 **30-31**

- See Single Edge Flat Slide features.

PINION  **47**

- Hardened teeth for long life.
- Stainless steel available in some sizes.
- Shaft Type Pinion available for Hepco Rack Driven Carriages. Please refer to  48.

SINGLE EDGE FLAT SLIDE  **30-31**

- Lower weight for less inertia where Slide is the moving component.
- Lower cost in cases where spacer is part of customer's construction.
- Plain hole, or counterbored fixing option for flush top surface.
- Single Edge Flat Slides can be spaced apart for high moment load capacity.

STANDARD CARRIAGE  **22-23**

- Factory adjusted to chosen Slide, if required.
- Carriage Plate available as an individual item, for self assembly.
- Useful size platform with flush surface and tapped holes for mounting purposes.
- Available with Bearings only, or with the addition of Cap Seals or Lubricators.
- Controlled height option for special accuracy requirements.
- Removable option for direct disengagement from Slide.

SEE APPLICATION
EXAMPLES SECTION
FOR DESIGN IDEAS

LUBRICATOR  **40**

- Lubricates contact surfaces, increasing load capacity and life.
- Long lubrication interval.
- Lightly sprung felt wiper ensures low friction.
- Can be attached from either side of a Carriage.
- Flanged and Compact versions available.



DOUBLE EDGE SPACER SLIDE  **26-27**

- Mounts directly to a flat surface. No spacer required.
- Keyway and datum edges provide means of location and alignment.
- Can be supplied with Rack mounted on top surface.
- Counterbored hole fixing, tapped hole fixing or undrilled options available.

CAP SEAL  **38**

- Lubricates contact surfaces, increasing load capacity and life.
- Lubricated for life in most applications.
- Seals against ingress of debris.
- Improves operational safety.
- Incorporates both through hole and tapped hole fixing facility.

STANDARD BEARING FIXING TYPES  **34-35**

- Concentric axle type provides datum for the system.
- Eccentric axle type provides adjustment for the system.
- Two axle lengths available, long & short.
- Controlled Height option improves system height accuracy.
- Blind Hole Fixing types (see  2).
- Double eccentric axle version available to enable direct removal of Carriage from a Slide. Useable only with Removable Type Carriage, due to hole positions. Please refer to the GV3 Technical Guide .

TWIN BEARING (shown left)

DOUBLE ROW BEARING (shown right)  **34-35**

- Twin Bearing for tolerance of misalignment and smooth running.
- Double Row Bearing for debris tolerance and higher load capacity.
- Special raceway conformity and low radial clearance.
- Metal shields for exclusion of particulates and low friction running.
- Nitrile sealed version prevents ingress of liquids.
- Lubricated for life internally.

Linear Motion System with Slimline Bearings

INDIVIDUAL COMPONENTS,
OR FULLY-ASSEMBLED
AND ADJUSTED SYSTEMS,
READY TO INSTALL

ALL SLIDES (COMMON FEATURES)  26-31

- All Hepco Slides are suitable for both Slimline and Standard Bearings. Please see features  2.

DOUBLE EDGE SPACER SLIDE  26-27

- Please see features  3.

SLIMLINE BLIND HOLE BEARING  36-37

- Please see features  2.

SINGLE EDGE SPACER SLIDE  28-29

- Please see features  2.

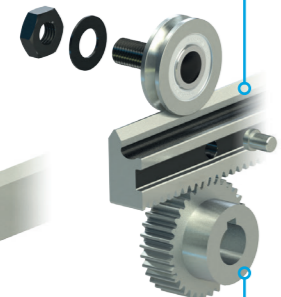

PINION  47

- Please see features  2.

SINGLE EDGE FLAT SLIDE  30-31

- Please see features  2.

DOUBLE EDGE FLAT SLIDE  30-31

- Please see features  2.

SLIMLINE BEARING FIXING TYPES  36-37

- Concentric axle type provides datum for the system.
- Eccentric axle type provides adjustment for the system.
- Two axle lengths available, long & short.

SLIMLINE BEARING  36-37

- Special raceway conformity and low radial clearance, for Slide applications.
- Narrow profile for compact system height.
- Low cost system, especially if combined with P3 grade (unground) Slides.
- Load capacity adequate for many applications.
- Single piece Bearing for tolerance of debris.
- Metal shields for exclusion of particulates and low friction running.
- Nitrile sealed version prevents ingress of liquids.

SLIMLINE CARRIAGE  24-25

- Factory adjusted to chosen Slide, if required.
- Carriage Plate available as an individual item, for self assembly.
- Useful size platform with flush surface and tapped holes for mounting purposes.
- Available with Bearings only, or with the addition of Cap Wipers or Lubricators.

SLIMLINE LUBRICATOR  40

- Please see features  3.

DOWEL PIN  27 & 29

- Easy method of location and alignment.

CAP WIPER  39

- Lubricates contact surfaces increasing load capacity and life.
- Lubricated for life in most applications.
- Inhibits against ingress of debris.
- Improves operational safety.
- Enhances appearance of system.
- Incorporates both through hole and tapped hole fixing facility.

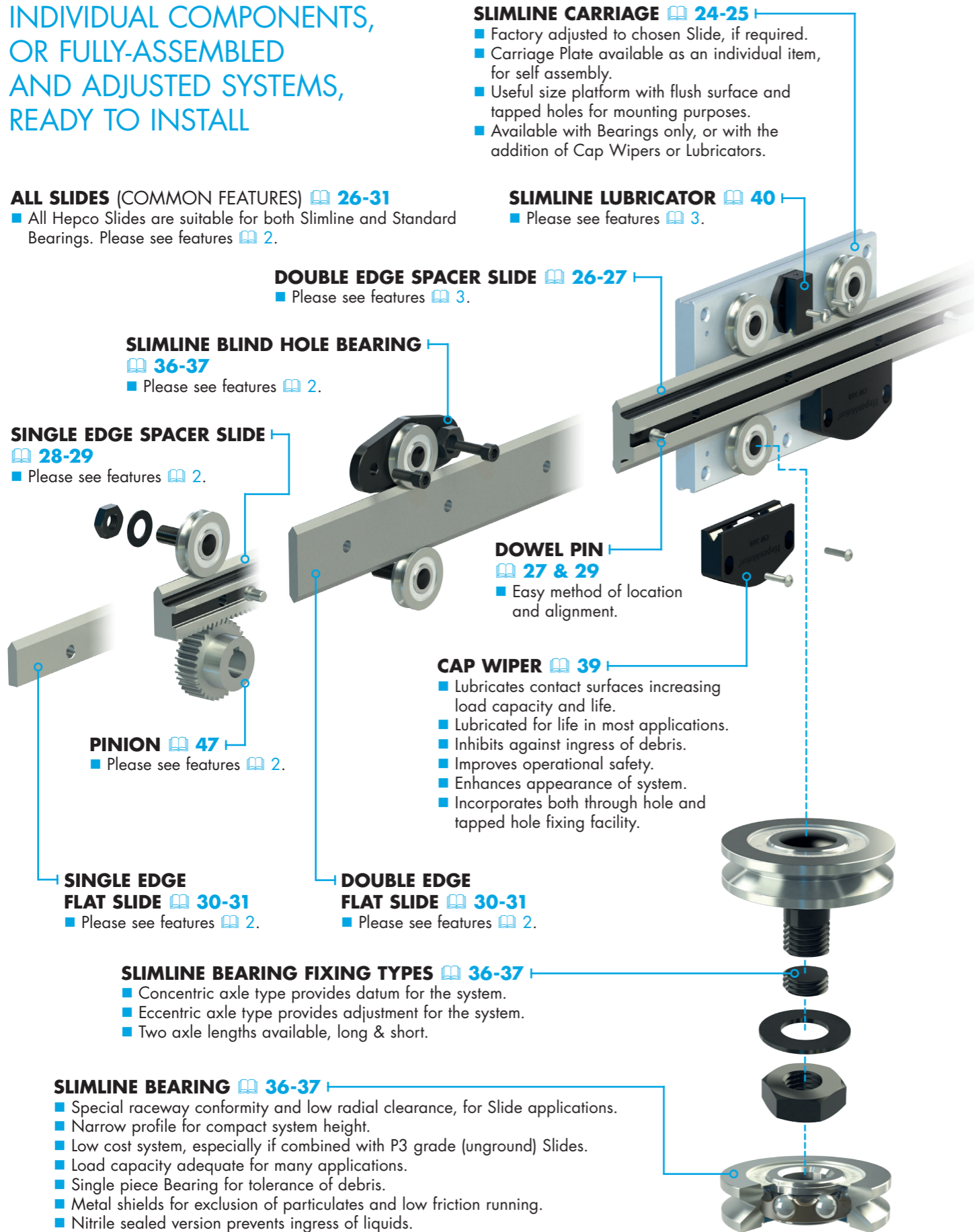

Linear Motion System with Flat Track & Rollers

SEE APPLICATION
EXAMPLES SECTION
FOR DESIGN IDEAS

TRACK ROLLERS (COMMON FEATURES)  43-45

- Size and load capacity equivalent to Hepco 'V' Bearings.
- Special raceway conformity with low radial clearance.
- Crowned running face for tolerance of misalignment.
- Metal shields for exclusion of particulates and low friction running.
- Nitrile sealed version prevents ingress of liquids.
- Designed to run on Flat Track or back face of Single Edge Spacer Slides.

WIDE TRACK ROLLER  44-45

- Concentric axle type (shown above Flat Track) provides datum for the system.
- Eccentric axle type (shown below Flat Track) provides adjustment for the system.
- Two axle lengths available, long & short.

BLIND HOLE WIDE TRACK ROLLER  44-45

- For mounting into thick plates or where access to opposite side is restricted.
- Adjustable from operating side, for ease of access.
- Concentric axle type Eccentric axle (adjustable) type

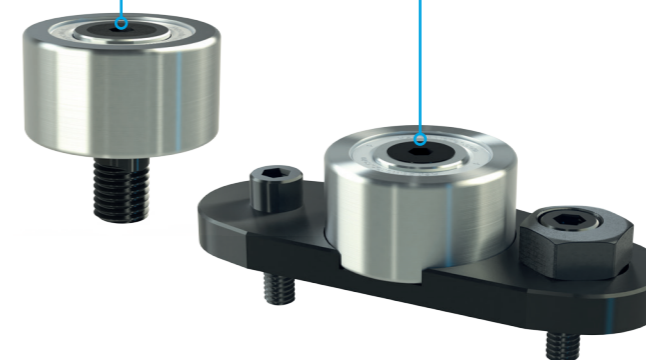

FLAT TRACK  42

- Choose from ground all over, ground on opposing faces, or unground.
- Deep hardened faces for maximum wear resistance.
- Manufactured from high quality carbon steel.
- Offset fixing holes for versatility of mounting.
- Four useful sizes compatible with Hepco 'V' Slides.
- Any length supplied up to 4 metres in most sizes.
- Unlimited length achieved by butting.

SINGLE EDGE SPACER SLIDE &
CONCENTRIC V BEARING

- Please see  4 for features and page references.

NARROW TRACK ROLLER  43

- Concentric axle type provides datum for the system.
- Eccentric axle type provides adjustment for the system.

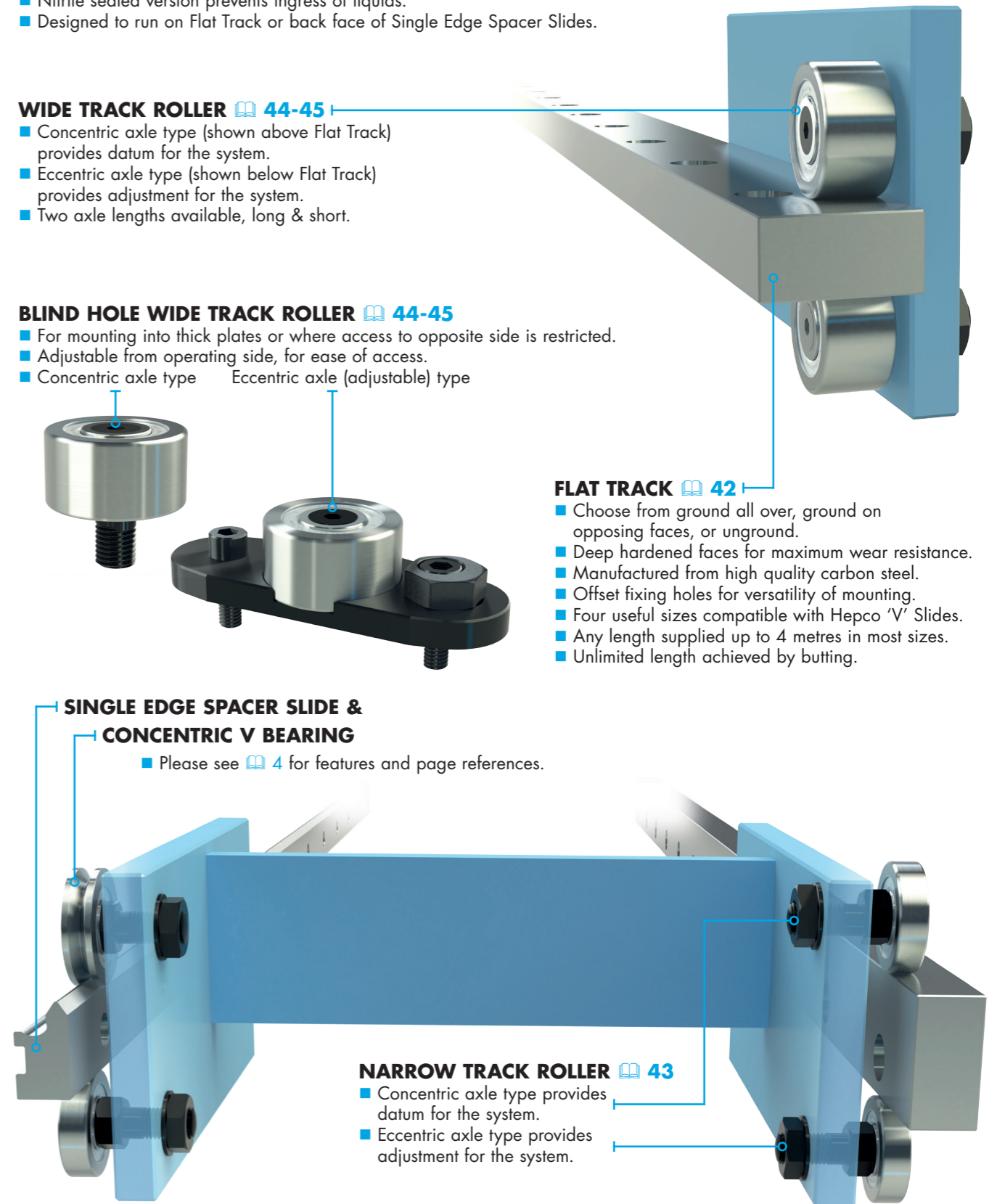

Linear Motion System with Drive Facility / Support Structure

INDIVIDUAL COMPONENTS,
OR FULLY-ASSEMBLED
AND ADJUSTED SYSTEMS,
READY TO INSTALL

BELT DRIVEN CARRIAGE  [GV3 Technical Guide](#)

- Use with Flat Slides, Spacer Slides or Slide Beams in all grades of precision.
- Integral belt tensioners for ease of adjustment.
- Removable mounting platform for ease of customising.
- Tapped holes for convenience of attaching components.
- Available with most Hepco Standard Bearing variants and Lubrication Devices.

TIMING BELT

 [GV3 Technical Guide](#)

- High strength, steel reinforced AT profile open length belt.
- Cut to length, up to 50 metres.
- Widths to suit Hepco Belt Driven Carriages & Pulleys.

TIMING PULLEY

 [GV3 Technical Guide](#)

- Low backlash profile for high positional accuracy.
- Width to suit Belt Driven Carriages.
- Diameter enables belt return through Slide Beam.

SLIDE BEAM  [32-33](#)

- Can be used as a machine construction member.
- Strong section, spans wide gaps.
- Lightweight version available.
- Counterbored Slide version for belt support.
- Hollow centre for belt, cable or chain return.
- T-Slots for attaching components.
- Plastic T-Slot covers, T-Nuts and fixing clamps available.

RACK DRIVEN CARRIAGE  [48](#)

- Complete carriage assembly available to include Drive Flange, Pinion and AC Geared Motor, or Gearbox only. Items available separately for use in conjunction with Rack Cut Single Edge Spacer Slides or separate Racks.
- Fine adjustment facility for Pinion assures low backlash.
- Various drive positions and motor orientations available.
- Carriages available with all Standard Bearing types and Lubrication Devices.

SEPARATE RACK  [46](#)

- As used in Rack-Slide assembly.
- Lengths up to 1.83 metres, longer lengths achievable by butting.

RACK-SLIDE ASSEMBLY  [26-27](#)

- Dowelled Rack-Slide assembly is ready to fix to the mounting surface.
- Slides with compound Racks available up to 4 metres.
- Unlimited Rack-Slide length achieved by butting.
- Attractive, corrosion inhibiting black finish on unground Slide faces and on Rack.

PINION  [47](#)

- Please see features  [2](#).

Ancillary Components

FLOATING BEARING

 [GV3 Technical Guide](#)

- Provides axial movement (float) of the 'V' position to compensate for parallelism error when two Slides are mounted in parallel.
 - Caged needle roller bearing for high speed operation.
 - Nitrile seals to prevent ingress of debris.
 - Lubricated for life internally.
- See Application Examples  [12 & 15](#)

VACUUM AND EXTREME TEMPERATURE BEARING

 [GV3 Technical Guide](#)

- All stainless steel construction.
 - Grease types for either extreme high temperature or extreme low temperature applications.
 - Available in most GV3 sizes including Blind Hole Fixing versions.
 - Also available in Track Roller format.
- See Application Examples  [17](#)

TWIN TAPER ROLLER BEARING

 [GV3 Technical Guide](#)

- High strength Bearing with exceptional rigidity, for load capacity and life exceeding standard GV3.
 - Available in size 54 for use in conjunction with Side Adjusting Carriage.
- See Application Examples  [11](#)

MCS-GV3 CONNECTIVITY

 [GV3 Technical Guide](#)

- GV3 Spacer Slides and Flat Slides can be mounted to **Hepco MCS (Machine Construction System)** profiles.
 - Can be supplied factory-assembled, ready for installation.
 - Hepco T-Nut Strip provides a location for Spacer Slides and retains fastener positions in the event of disassembly.
 - Comprehensive range of aluminium profiles and Slide mounting combinations available, including Single Edge Slides.
- See Application Examples  [15 & 16](#)

SEE APPLICATION
EXAMPLES SECTION
FOR DESIGN IDEAS

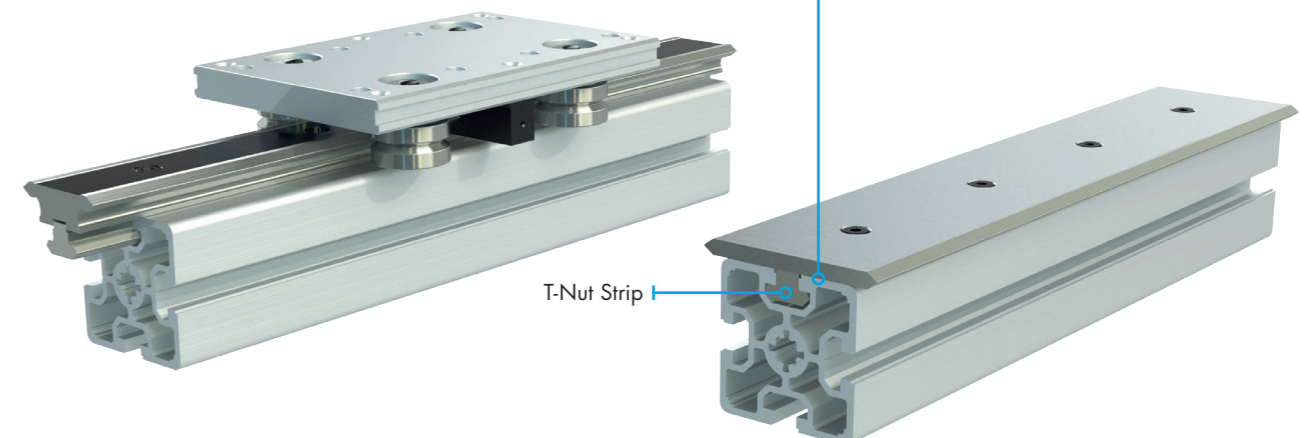
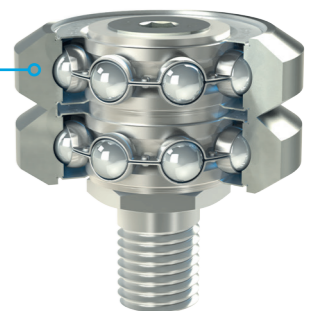
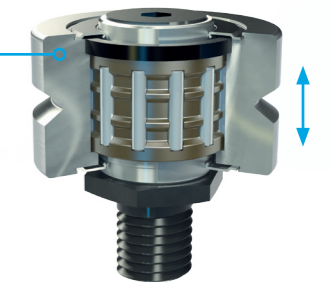

Ancillary Components

INDIVIDUAL COMPONENTS,
OR FULLY-ASSEMBLED
AND ADJUSTED SYSTEMS,
READY TO INSTALL

REMOVABLE CARRIAGE [↓ GV3 Technical Guide](#)

- Incorporates Double Eccentric Bearings to enable complete removal of the Carriage. Please see Side Access Adjustment below and in the GV3 Technical Guide [↓](#) for an alternative method of removal without having to first disassemble mounted components.

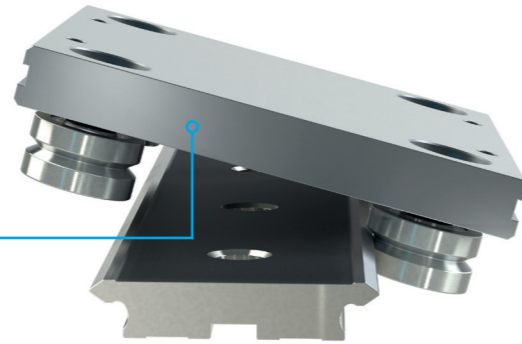

CARRIAGE WITH SIDE-ACCESS ADJUSTMENT [↓ GV3 Technical Guide](#)

- Alternative method of Bearing adjustment, allowing fine and controlled setting.
- Available with sizes Ø25, Ø34 and Ø54 Standard Bearings, and for Ø54 Twin Taper Roller Bearing.
- No necessity to remove customer components from the Carriage Plate when adjusting.
- Adjustment is sufficient to remove Carriage directly from the Slide.
- Secure setting. Will not alter under abnormal service conditions.
- Advantageous in applications where access required to adjust Standard Eccentric or Double Eccentric Bearings is limited.

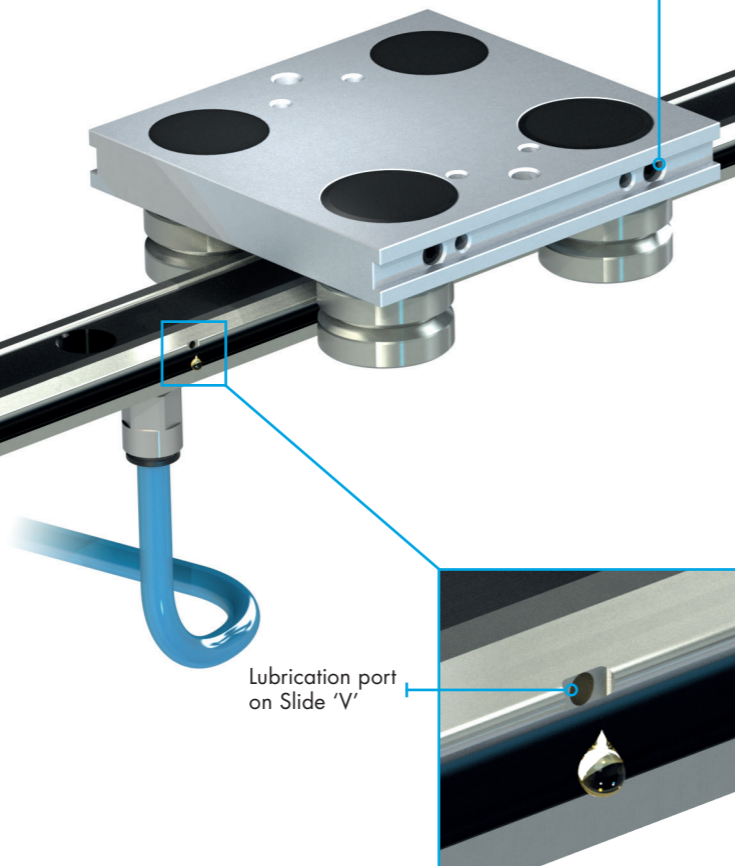

Lubrication port on Slide 'V'

BLEED LUBRICATION  41

- Channels lubricant directly to the 'V' surface of Slides.
- For connection to any centralised lubrication system, dispensing pump and controller or pressure feed canister.

FLANGE CLAMP

[↓ GV3 Technical Guide](#)

- Enables Slide to become a self supporting beam.
- Two mounting possibilities, face fixing or base fixing.
- Easy removal of Slide and positive relocation.
- Available in long or short type, to support a Slide at one or both ends.

END STOP [↓ GV3 Technical Guide](#)

- Provides a physical stop to the linear movement and impact protection should a system overrun.
- Conical buffer provides a controlled deceleration to the Carriage to protect the system and payload.
- May be positioned anywhere along the length of a Slide for maximum flexibility.

SEE APPLICATION
EXAMPLES SECTION
FOR DESIGN IDEAS

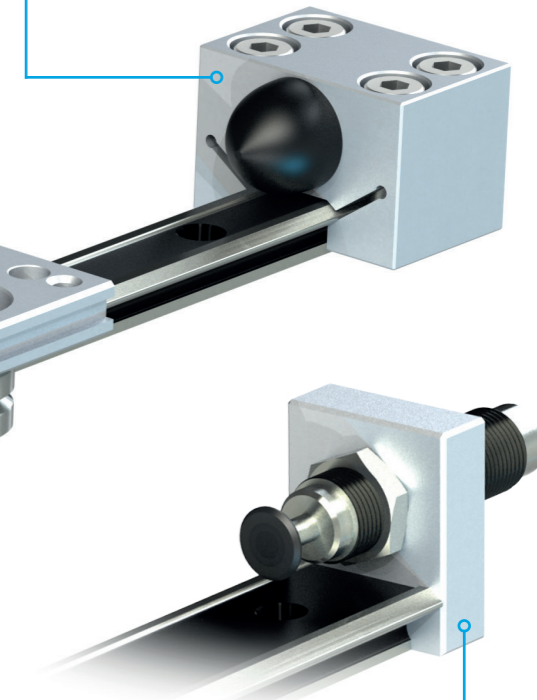

CARRIAGE LOCKING DEVICE

[↓ GV3 Technical Guide](#)

- Provides a safe and simple method of manually locking a Standard Carriage in position to facilitate processes where a secure, stationary platform is required.

MOMENT LOAD CARRIAGE

[↓ GV3 Technical Guide](#)

- Provides extra support and rigidity in applications where high downwards or offset loads are anticipated, typically at work stations.
- Two sizes of Carriage/Slide combinations available.
- Available with two types of work station support - static roller type and dynamic roller type (shown) - both designed to connect to a track system support beam.
- Single-roller or twin-roller configurations.
- Carriage locking system available for precise positioning of Carriage when stationary.

SHOCK ABSORBER

[↓ GV3 Technical Guide](#)

- Increases life of the Slide System by reducing stress on internal elements and reducing wear on the Slide in crucial deceleration zones.
- Permits higher operating speeds and reduces maintenance costs and noise levels.
- Enhances safety in the event of control system failure.
- Compatible with Standard and Slimline Carriages.
- Top mounting, end mounting or clamp mounting types available, according to Slide size and type.

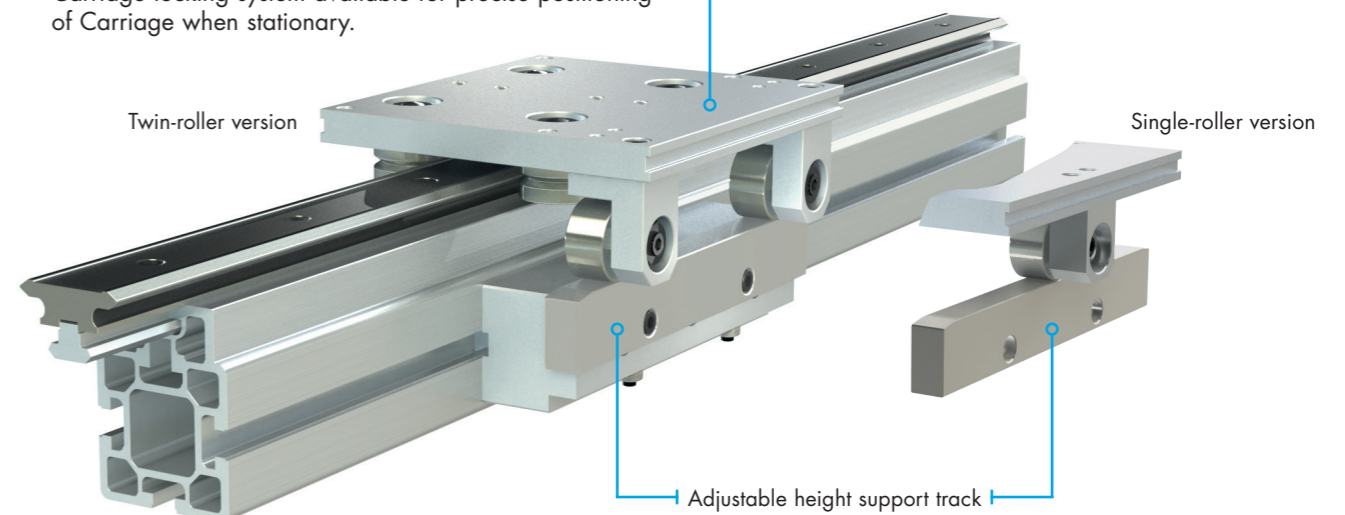

Twin-roller version

Single-roller version

Adjustable height support track

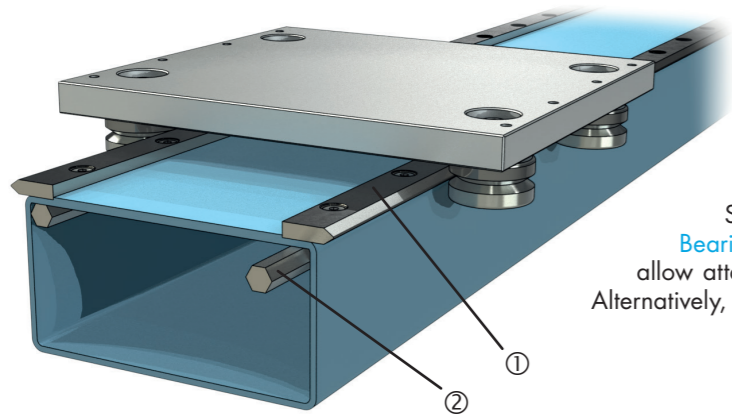

MOUNTING SLIDES ONTO TUBULAR FRAMEWORK

Hepco Single Edge Flat Slides ① can be mounted to the edges of many sizes of square or rectangular tube with sufficient protrusion of the Slide 'V' running face to provide clearance for Hepco Bearings and Lubrication Devices. The fixing hole positions allow attachment by means of standard sizes of hexagon bar ②. Alternatively, Slides can be attached by "flowdrilling" or by welding.

LOW HEIGHT SYSTEM

A very compact Slide System can be achieved by using Hepco Flat Slides ① in conjunction with Slimline Bearings ② and by choosing thin section material for the Carriage and Slide support.

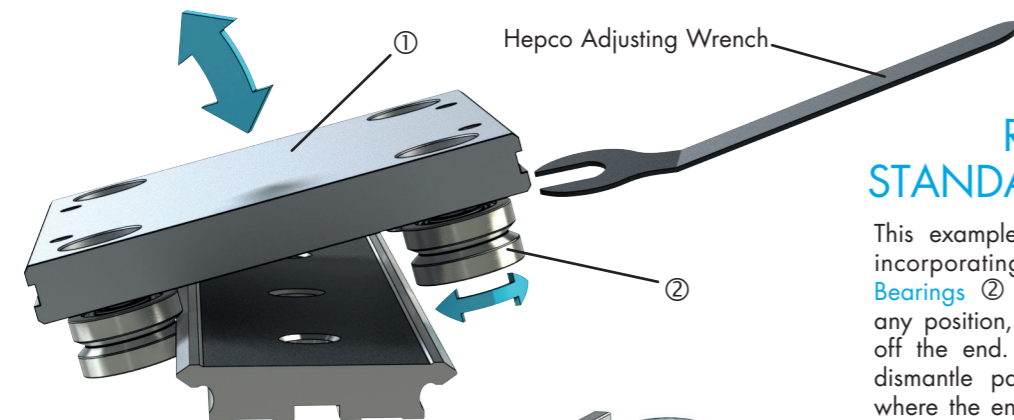
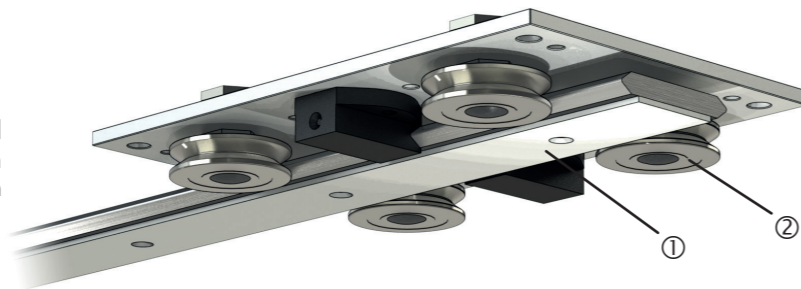

REMOVABLE TYPE STANDARD CARRIAGE

This example shows how a Carriage ① incorporating Double Eccentric type Bearings ② can be taken off a Slide in any position, without running the Carriage off the end. This facility saves having to dismantle part of the machine in cases where the ends of the Slide are "blocked".

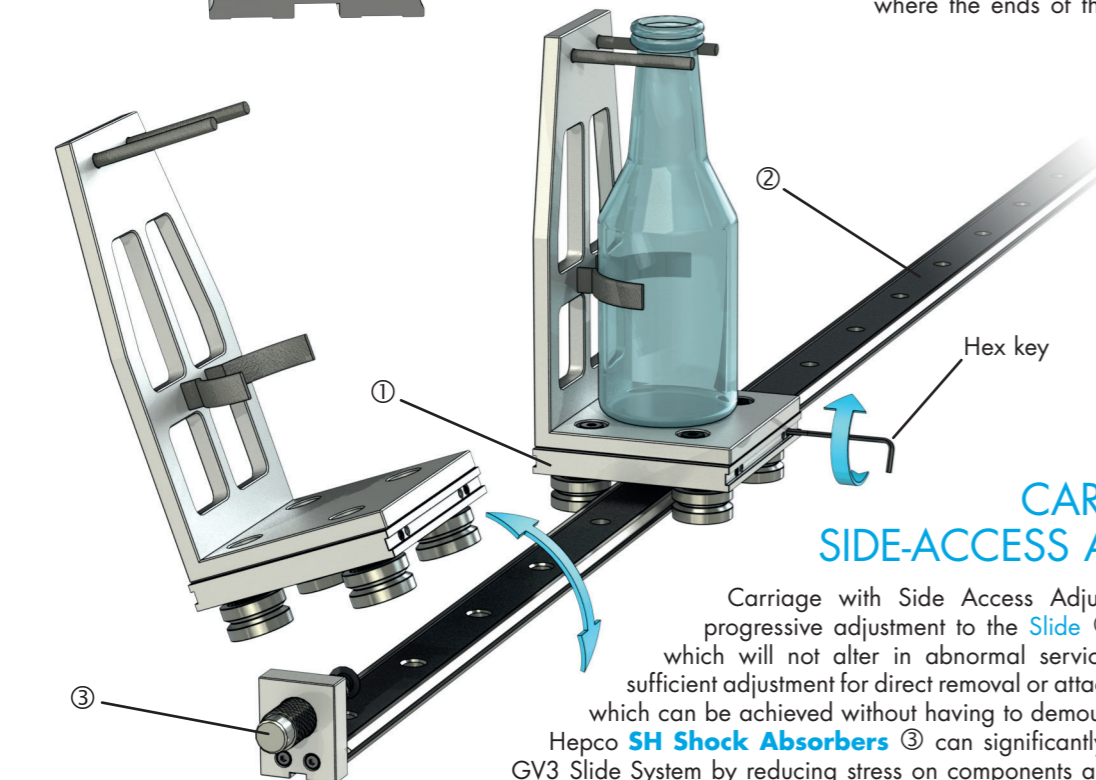

CARRIAGE WITH SIDE-ACCESS ADJUSTMENT

Carriage with Side Access Adjustment ① enables progressive adjustment to the Slide ② and positive setting which will not alter in abnormal service conditions. There is sufficient adjustment for direct removal or attachment of the Carriage, which can be achieved without having to demount the attached fixture. Hepco SH Shock Absorbers ③ can significantly increase the life of a GV3 Slide System by reducing stress on components and minimising wear on the Slide in the crucial deceleration zone.

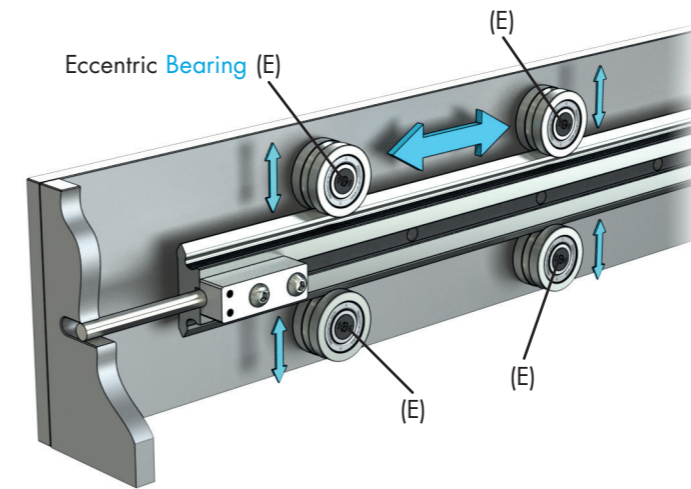

EASE OF ALIGNMENT USING ALL ECCENTRIC BEARINGS

This example shows the possibility to adjust the Hepco GV3 Slide System in one plane, thus avoiding the necessity for precision drilling and fitting.

LIGHT LOADS

Where very light loads are anticipated, three Bearings may be used instead of the usual configuration of four. This saves on component cost and assembly time.

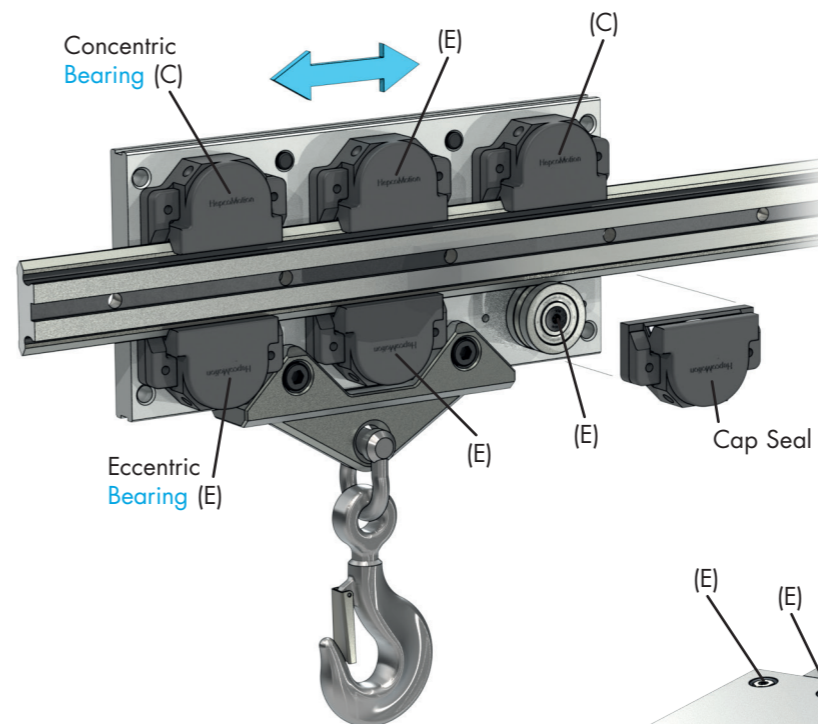
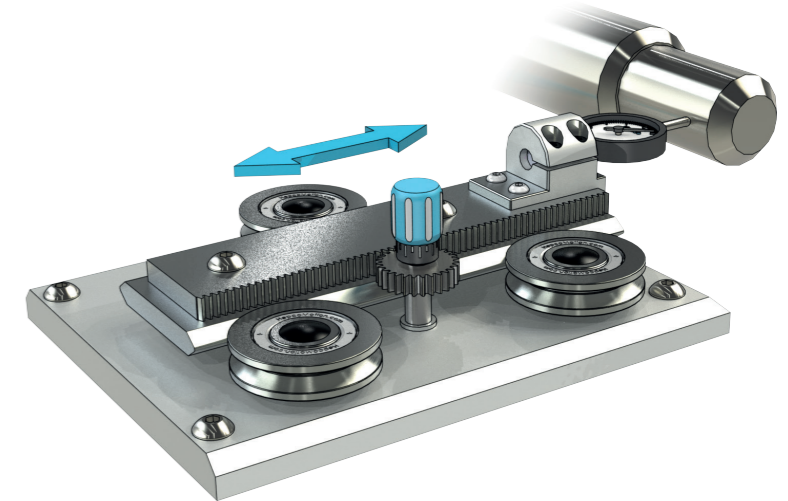

HEAVY LOAD REQUIREMENTS

For increased load capacity, additional Eccentric Bearings 'E' may be installed in between the outermost ones. Multiple Bearing installations benefit from the use of Controlled Height Bearings ④ which ensure better load distribution. Cap Seals will provide lubrication and maximise load capacity. Alternatively, Twin Taper Roller Bearings ⑤ or HDS2 Heavy Duty Linear Guide and MHD Track Roller Linear Motion systems may be used for very high load.

WIDE PLATFORM

Rigidity of a wide platform is achieved by mounting Slides in parallel. Single Edge Slides should be considered for long platforms.

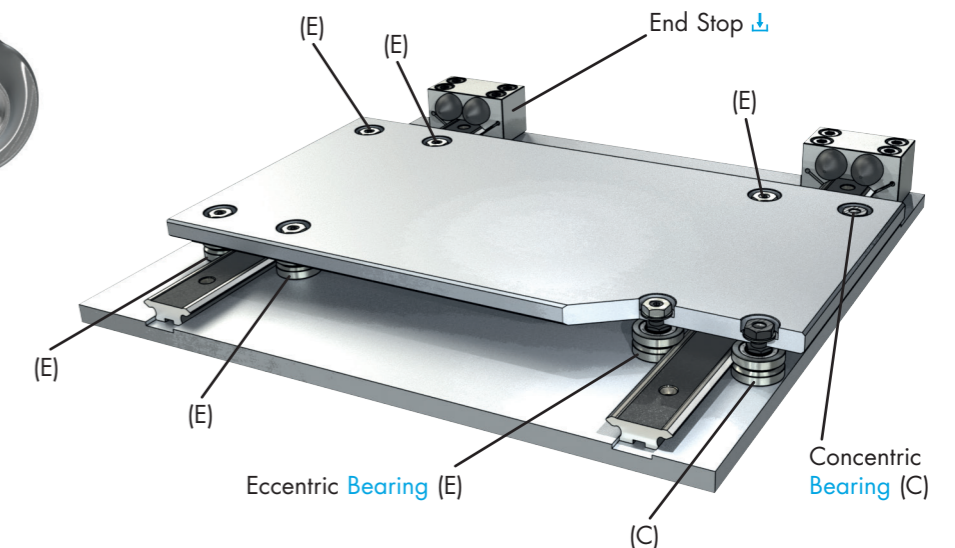

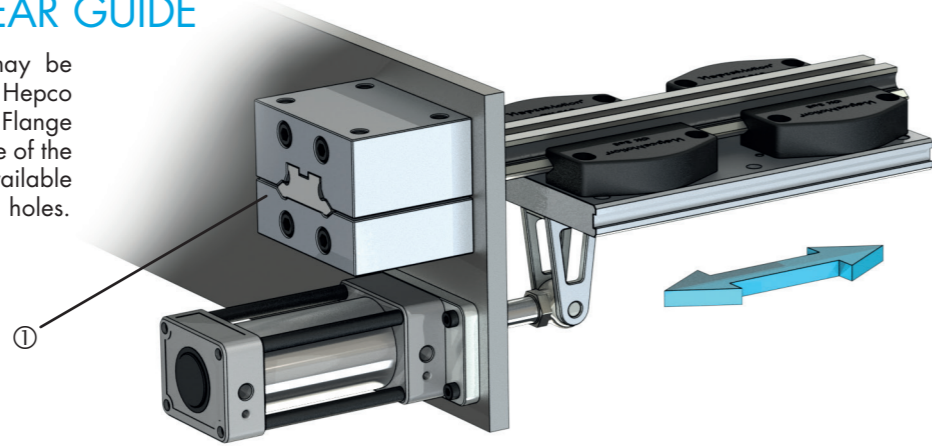

CANTILEVERED LINEAR GUIDE

Short stroke sliding movements may be supported from one end only, using Hepco long series Flange Clamps  ①. Flange Clamps may be bolted to either side of the supporting framework and are available with either through holes or tapped holes.



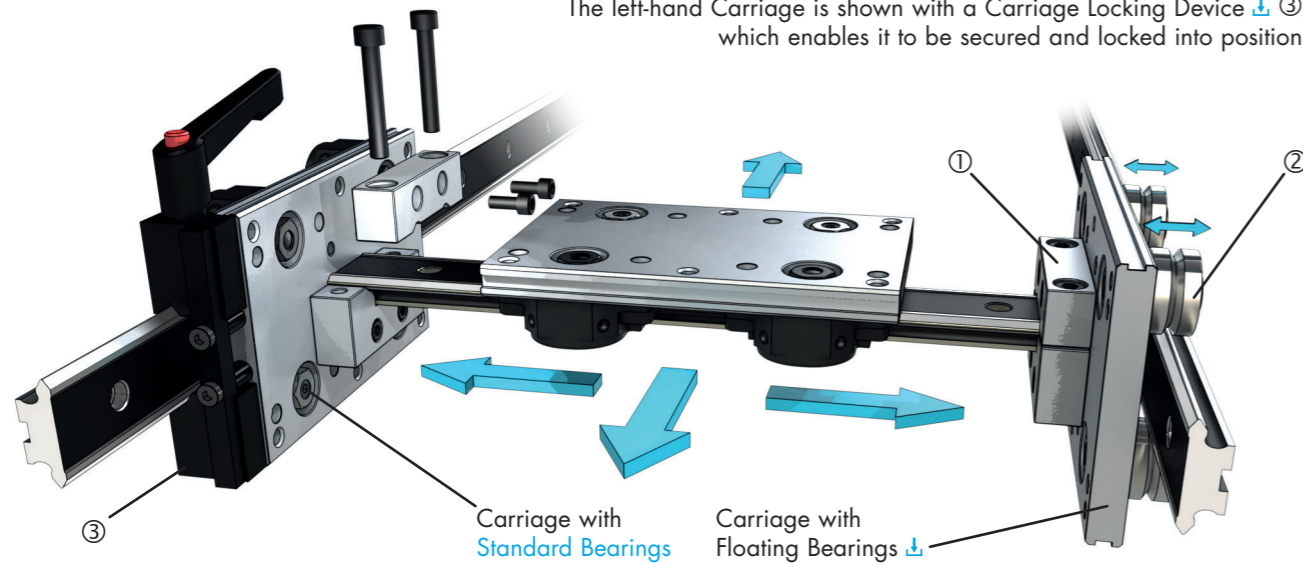

SIMPLE TWO AXIS CONNECTION

Hepco short series Flange Clamps  ① are an ideal method of connecting opposing Carriages and creating a second axis which can be easily installed or removed. To overcome the necessity to set opposing Slides parallel, Hepco Floating Bearings  ② are used on one side. The left-hand Carriage is shown with a Carriage Locking Device  ③, which enables it to be secured and locked into position.



MULTI-LANE ROW DIVIDER

Hepco Flange Clamps  ① can be used to support a Double Edge Spacer Slide  ② in a number of positions by utilising the base mounting facility. No oil is permitted in this example so Bearings  ③ are used without Cap Seals or Lubricators. The GV3 system is well suited to run "dry", especially in lighter duty applications.

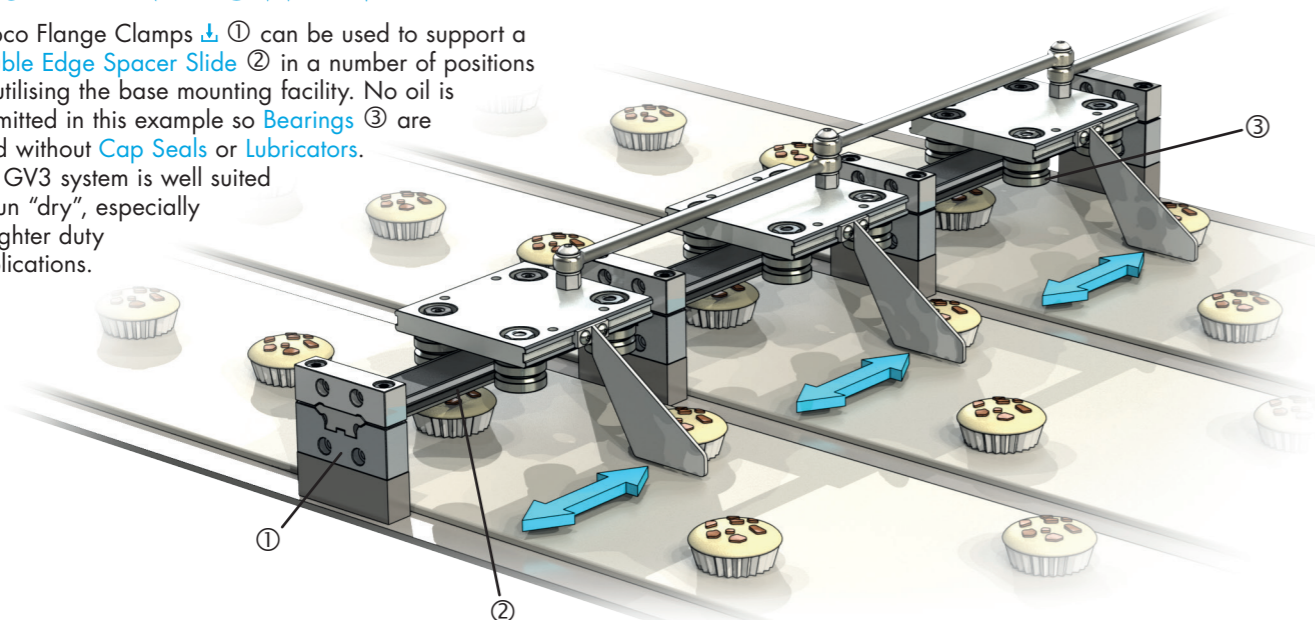

HIGH SPEED AIR FLOW TESTING

Hepco Slide Systems are capable of continuous operation at extremely high speeds. The factor which limits speed is the build up of heat in the Bearings. Intermittent use as in the application allows the heat to disperse and hence makes even higher speeds possible.

Acceleration and deceleration should be controlled in order to avoid Bearings skidding on the Slide.

This application shows a very long system using Hepco Double Edge Flat Slides  ① with the test piece mounted onto a Belt Driven Carriage  ②.

Lubricators  ③ apply a film of oil to the 'V' faces of the Slide without imposing undue friction.

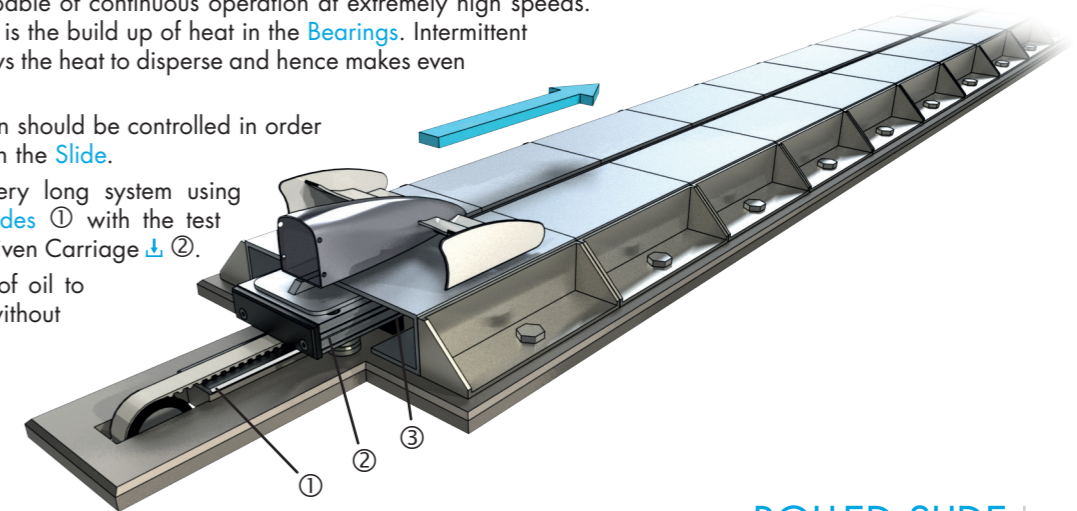



ROLLED SLIDE

Hepco Flat Slides  ① can be rolled to any diameter above 600mm depending on the section and whether hardened or not (unhardened Slides available to special order). Also, Slides in an unrolled condition may be bolted to a gently curved surface. Bearing mounting faces on the Carriage should be machined so that each pair of Bearings is perpendicular to the Slide. Please contact Hepco for application advice.

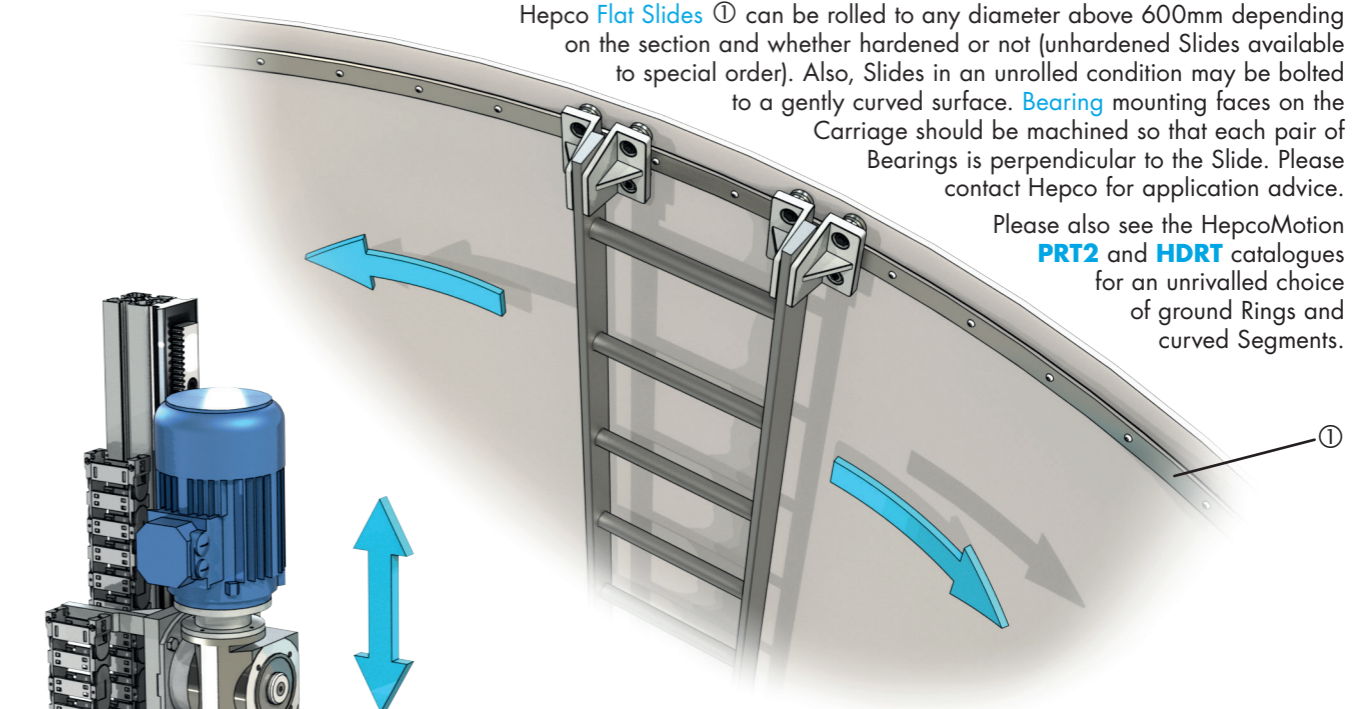
Please also see the HepcoMotion PRT2 and HDRT catalogues for an unrivalled choice of ground Rings and curved Segments.



DIPPING SYSTEM

A basket of parts is lowered into a vat by means of a Rack Driven Carriage  ① and Rack Mounted Slide  ②, available from Hepco as a complete unit. The system includes AC Motor, Gearbox and Pinion with micro adjustment for correct tooth engagement. The system is able to withstand high transmission forces and provides a low cost reliable solution capable of working in a hostile environment.

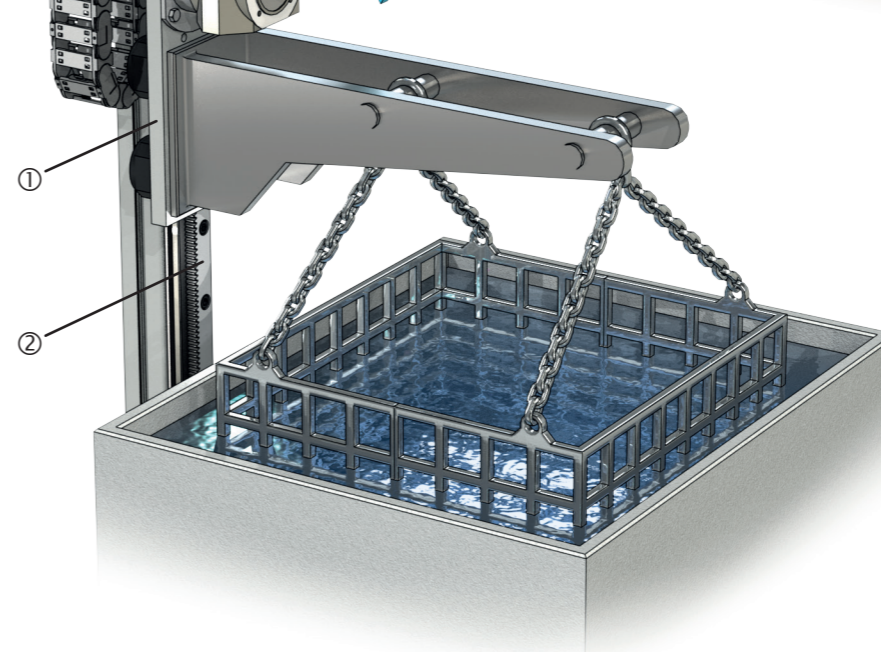

REMOTE CONTROLLED CAMERA

Hepco Slides are used extensively in the theatre and film industry for positioning cameras or lighting. This example shows a Hepco Slide Beam ① with flush Slide surface for engagement with a friction drive roller. The Slide Beam which is attached to the ceiling members, provides a rigid foundation and absorbs vibration.

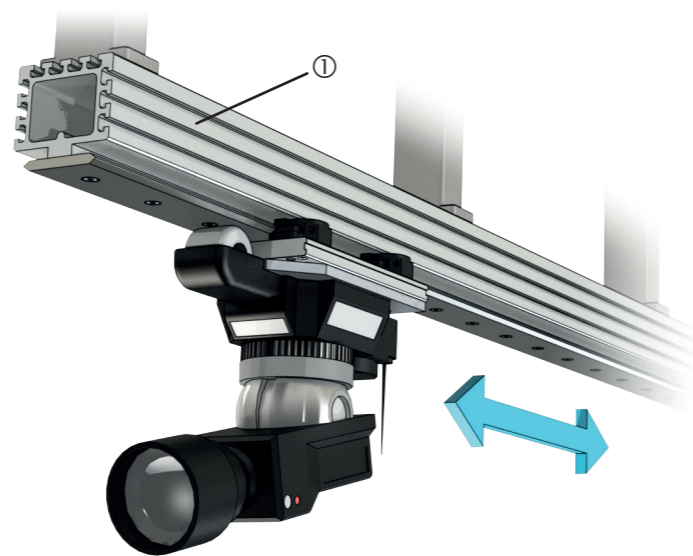

TELESCOPIC PICK AND PLACE GANTRY

The telescopic beam can travel alternately either side of the support column, between production lines, enabling components to be moved from one line to the other.

The beam retracts out of the paths of adjacent production lines, enabling components to be moved from one line to another without interrupting flow.

Primary X axis: Double Edge Spacer Slides ① are mounted back to back, sandwiching the support plate for the Hepco Racks ②, providing a compact design and a rigid beam.

Secondary X axis: The gripper mechanism is driven end-to-end along the beam by motor and Pinion engaged in the secondary Rack.

Z axis: A Hepco 120mm wide Spacer Slide with Rack ③ is chosen for the vertical axis to withstand the high moment forces involved.

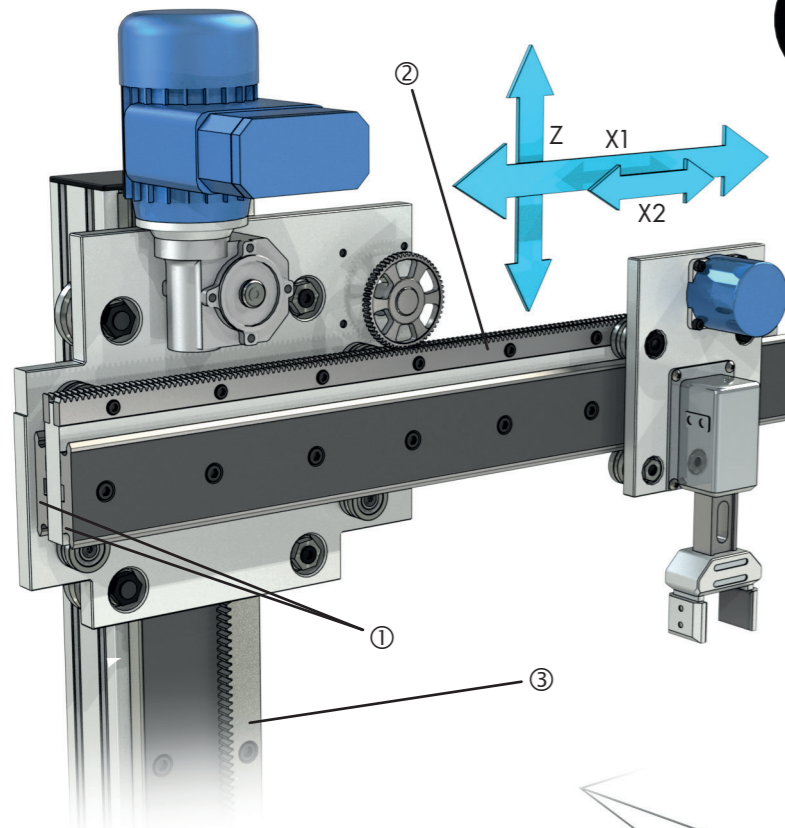

PULVERISING MACHINE

Hepco Slide Beams ① complete with Belt Driven Carriages ② enable a simple contra-reciprocating motion to be achieved. The high stiffness of the Slide Beams contribute to the rigidity of the structure and absorb vibration. The unique belt tensioning device within the Carriage enables easy adjustment and positioning of the pulverising combs. Hepco Cap Seals ③ ensure long life without further re-lubrication in this application and prevent debris entering the Bearings.

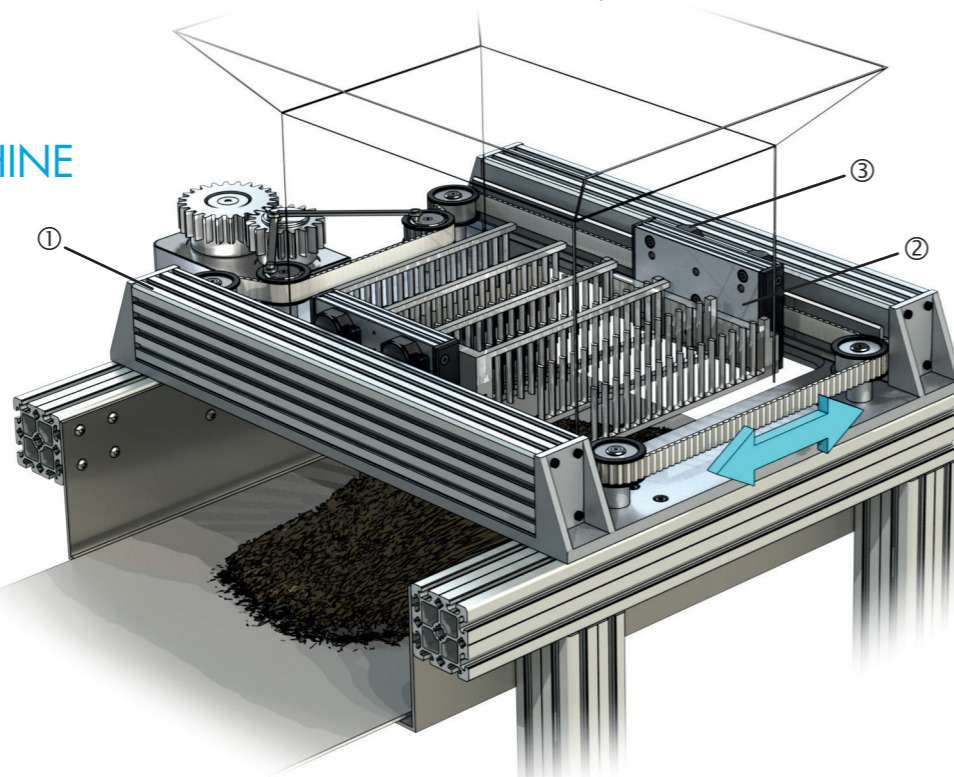

HIGH SPEED MARKING MACHINE

X axis: The Hepco Double Edge Spacer Slide with Rack ① assures parallelism between teeth and 'V' faces of the Slide, providing smooth motion with low backlash. Hepco Floating Bearings ④ mounted on one side allow for imperfection of parallelism between the opposing X axis Slides to be accommodated. Hepco MCS Machine Construction System profiles with T-Nut fixing facility ② provide a useful method for attaching the X axis Slides. Please see GV3 Technical Guide ④.

Y axis: Hepco Single Edge Spacer Slides are mounted wide apart for increased stiffness. The lower Rack Cut Slide ③ enables direct drive via a Hepco Pinion.

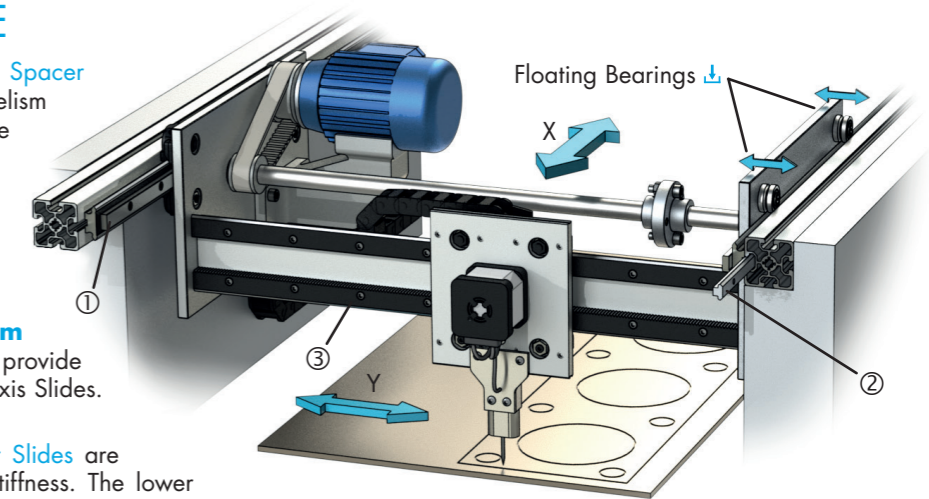

COMPACT RACK DRIVEN X-Z MOVEMENT

X axis: Outward facing Single Edge Spacer Slides ① are mounted sufficiently far apart to provide the required rigidity and to accommodate the drive Pinion. A compact design is achieved by mounting the Bearings on a common plate, which also supports the Slides for the Z axis.

Z axis: Inward facing Single Edge Spacer Slides allow the motor and drive Pinion to be accommodated adjacent to the gripper housing. Blind Hole Fixing Bearings ② are used as through hole fixing is not possible.

Lubricators ③ are used throughout for friction free application of oil to minimise risk of stalling the stepper motors.

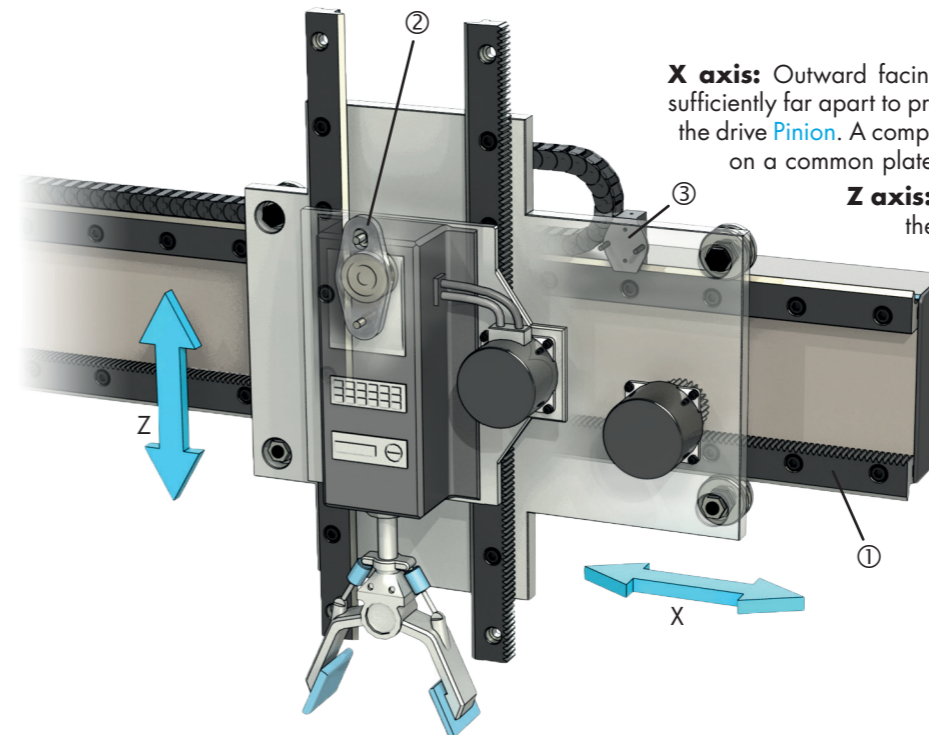

TELESCOPIC LOADER

Hepco Flat Slides ① combined with Slimline Bearings ② produce a low profile Slide System enabling a compact telescopic system to be designed. Hepco Racks ③ are easily incorporated to provide an efficient means of driving via Pinions of a suitable ratio.

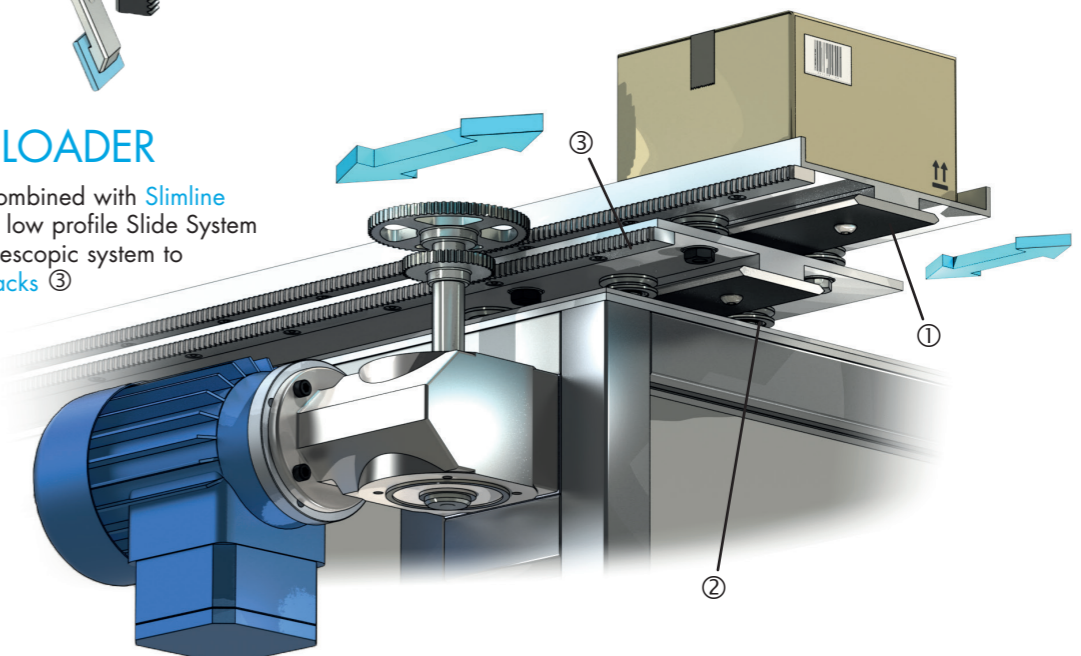

MULTI AXIS ROBOTIC ARM

A number of axes can be built up in a compact manner by using **Single Edge Spacer Slides** ① spaced apart to accommodate platforms sufficiently large to support the adjacent axis. The rotary turn-table is also easy to construct by using components selected from Hepco's **PRT2 Precision Ring & Track System** product range.

The vertical axis supporting the robotic arm is fixed to the rotary table by a Hepco long series **Flange Clamp** ②.

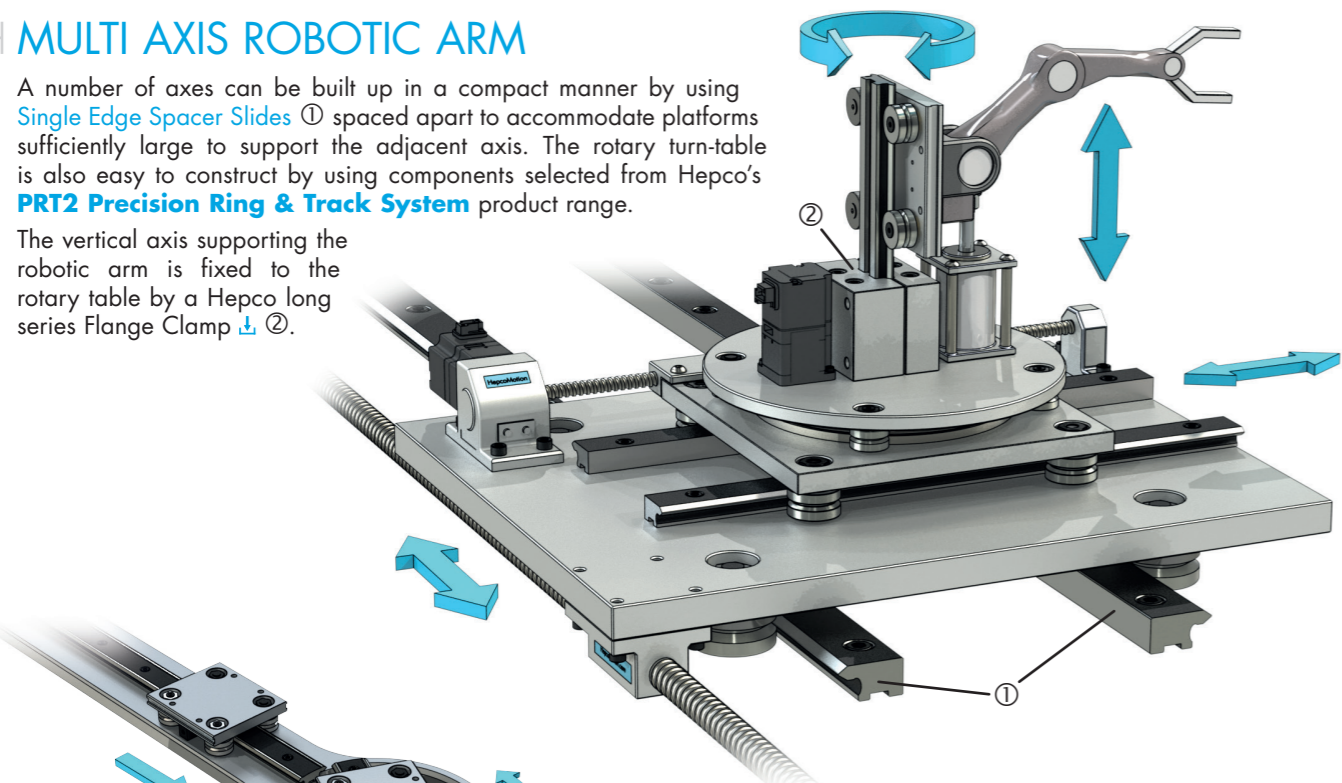

INCORPORATING TURNABLES

The unique ability of Hepco GV3 **Carriages** to traverse from one **Slide** to another makes it possible to incorporate turntables into a system. This can enable a **Carriage** to be re-directed to a station point, or its orientation reversed on the **Slide**. This example illustrates the use of Hepco's PRT2 **Ring Disc** ① (see separate **PRT2** catalogue) to provide the rotary movement and platform for the turntable. Various drive methods are possible, including friction belts and pusher mechanisms.

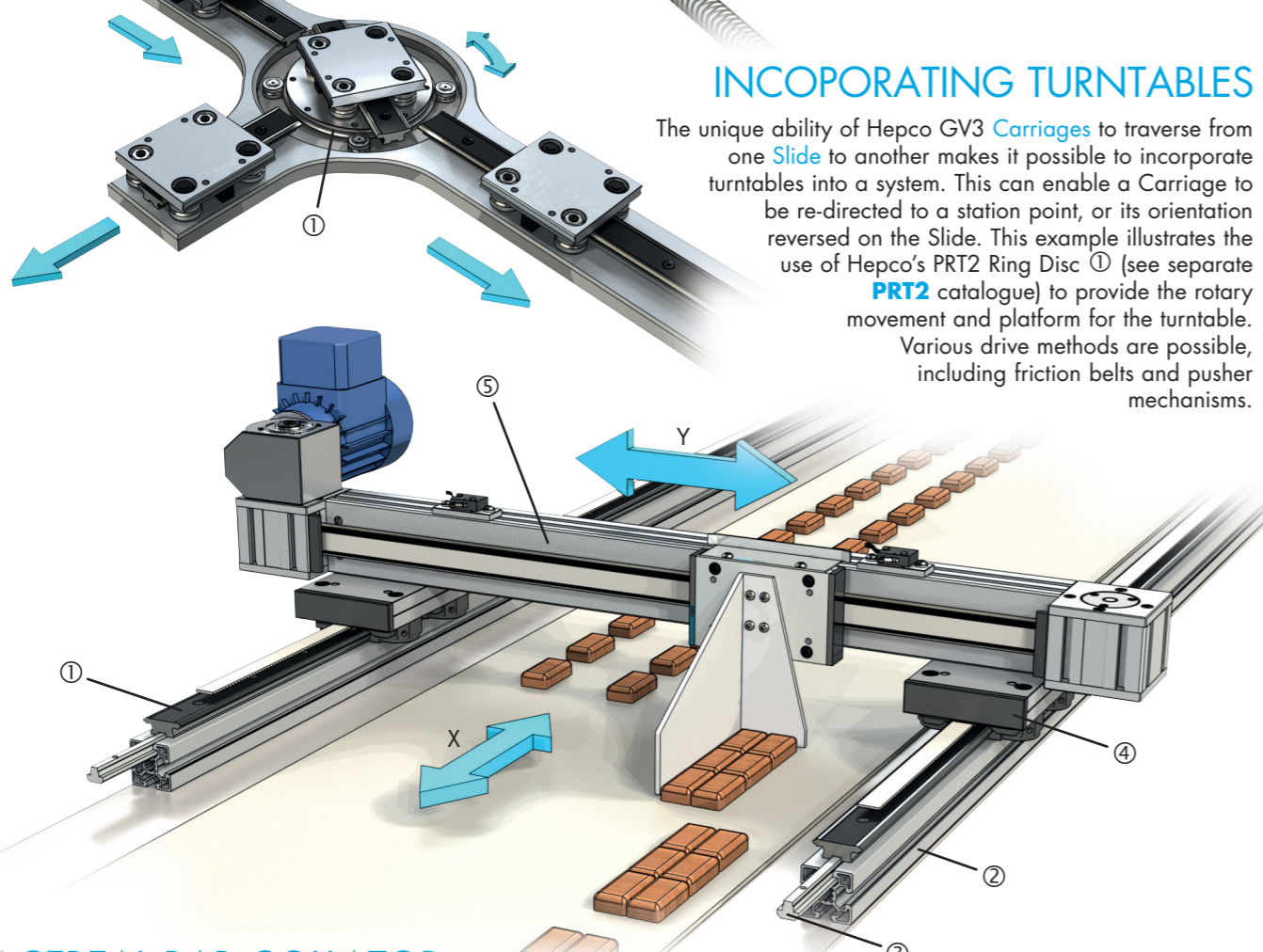

CEREAL BAR COLLATOR

X axis: Hepco **Spacer Slides** ① attach to Hepco **MCS Machine Construction System** aluminium profiles ② by means of Hepco T-section location strip ③. Hepco **Belt Driven Carriages** ④ incorporate an easy means of tensioning as well as providing support for the Y-axis.

Y axis: Comprises a Hepco **DLS Driven Linear System** unit ⑤, which is a complete linear motion element with pulleys, switch components and motor gearbox, if required. Please see separate **DLS** catalogue.

MULTI STATION PRODUCT PICKING AND COLLATING SYSTEM

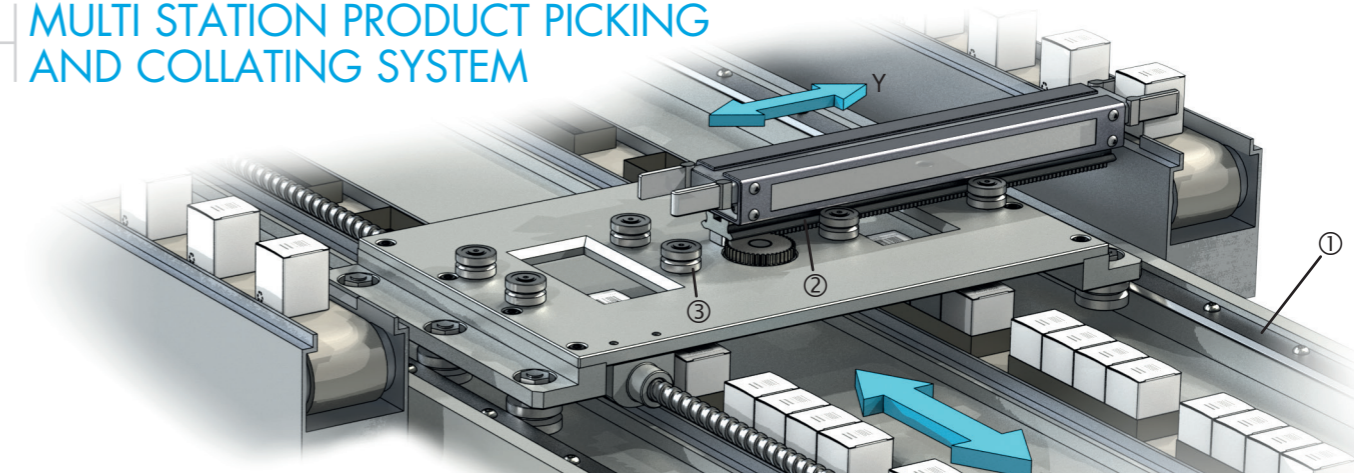

X axis: Hepco **Single Edge Flat Slides** ① bolt direct to the machine frame to achieve a simple low cost design. Hepco **Bearings** are fixed to the carriage structure, which spans the collation conveyor and provides room for the drive. Three **Bearings** are fitted each side to support the load, due to the height restriction preventing the usual configuration of two larger size **Bearings** per side.

Y axis: Guidance for the product picking device is provided by Hepco **Double Edge Spacer Slide** with **Fitted Rack** ② to enable drive via a Hepco **Pinion**. The **Slide** runs in a "railway" of **Controlled Height Twin Type Bearings** ③, which ensure alignment and compliance as the **Slide** engages. All **Eccentric type Bearings** are used except the two outermost on one side, which are the **Concentric type** in order to provide a datum for the system.

TRAVERSING A GAP

In this example, a special **Six Bearing Carriage** moves in and out of a chamber, traversing a gap between two **Slides** to provide room for a sealing door to close. The **Slides** have a special tapered lead-in profile for smooth transition.

For vacuum applications, Hepco **Extreme Temperature & Vacuum Bearings** ④ are available, in addition to Hepco's **SL2 Stainless Steel Linear Guide** product range.

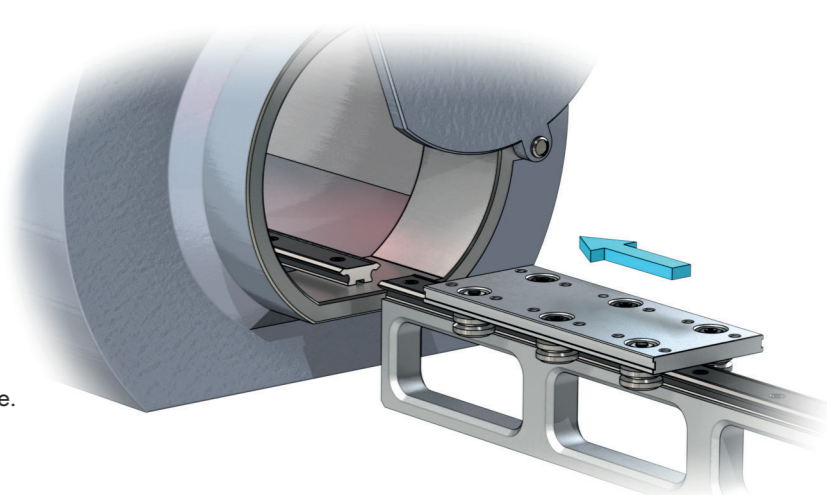

TRANSPORT SYSTEM

A unique feature of the Hepco GV3 system is the ability of a **Slide** to be moved into near perfect alignment with another **Slide** for smooth transfer of **Carriages**. It is therefore possible to switch lanes and change direction. This example shows **Carriages** being driven by friction belt onto a **Slide**, which is then elevated to another level. **Carriages** are cycled around the system, maintaining the same orientation. Customers requiring high speed operation with orientation in the direction of travel, should consider Hepco's **PRT2 Precision Ring and Track System** product range.

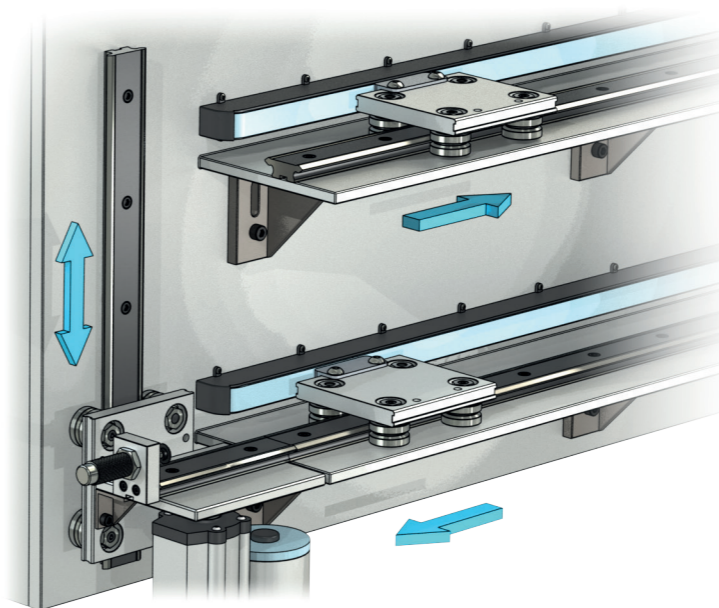



SHOWN HERE ARE FULL SIZE ILLUSTRATIONS OF ALL SLIDES AND ALL BEARINGS PLUS SOME OF THE MORE POPULAR ASSEMBLED CARRIAGES

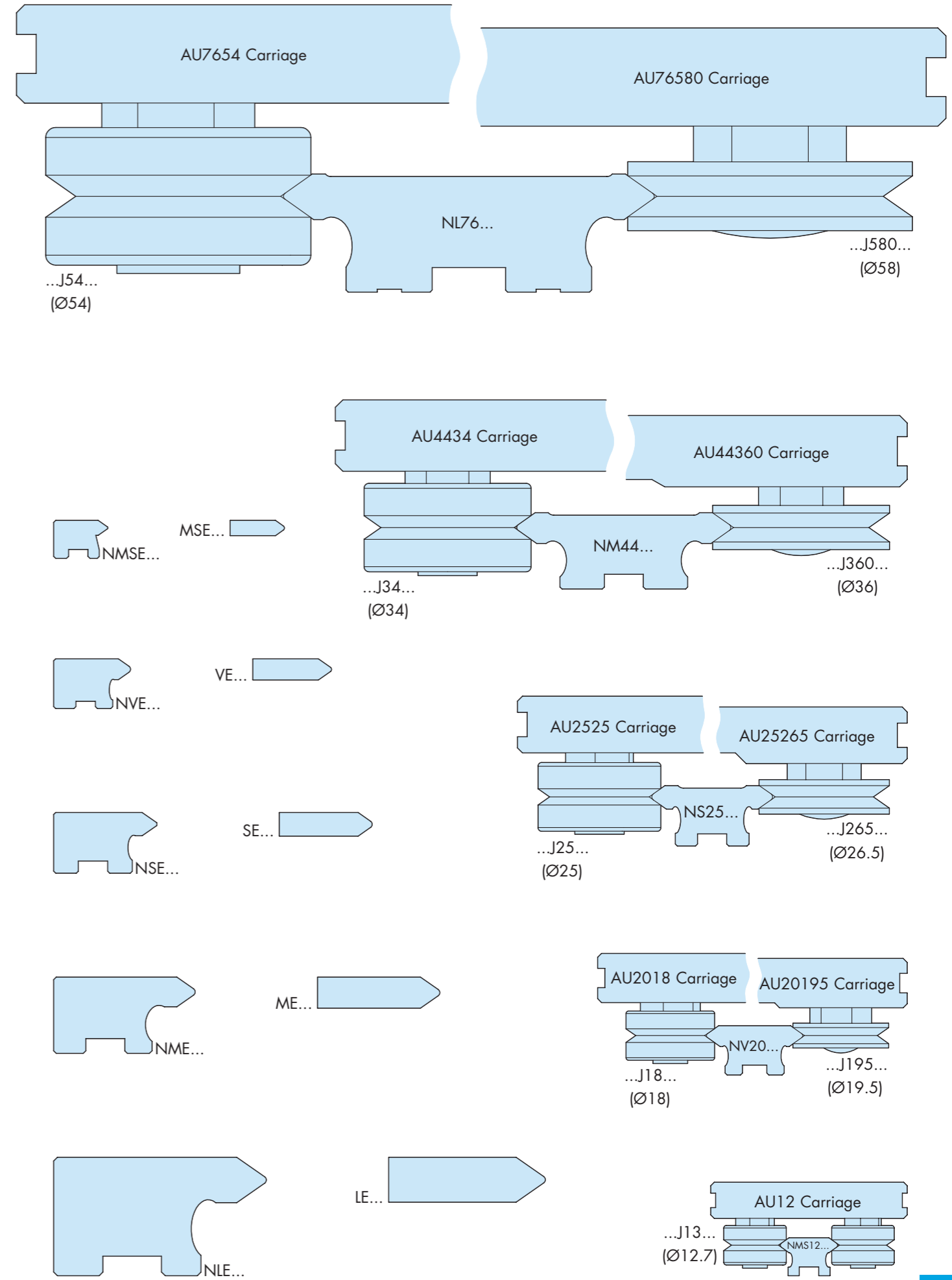
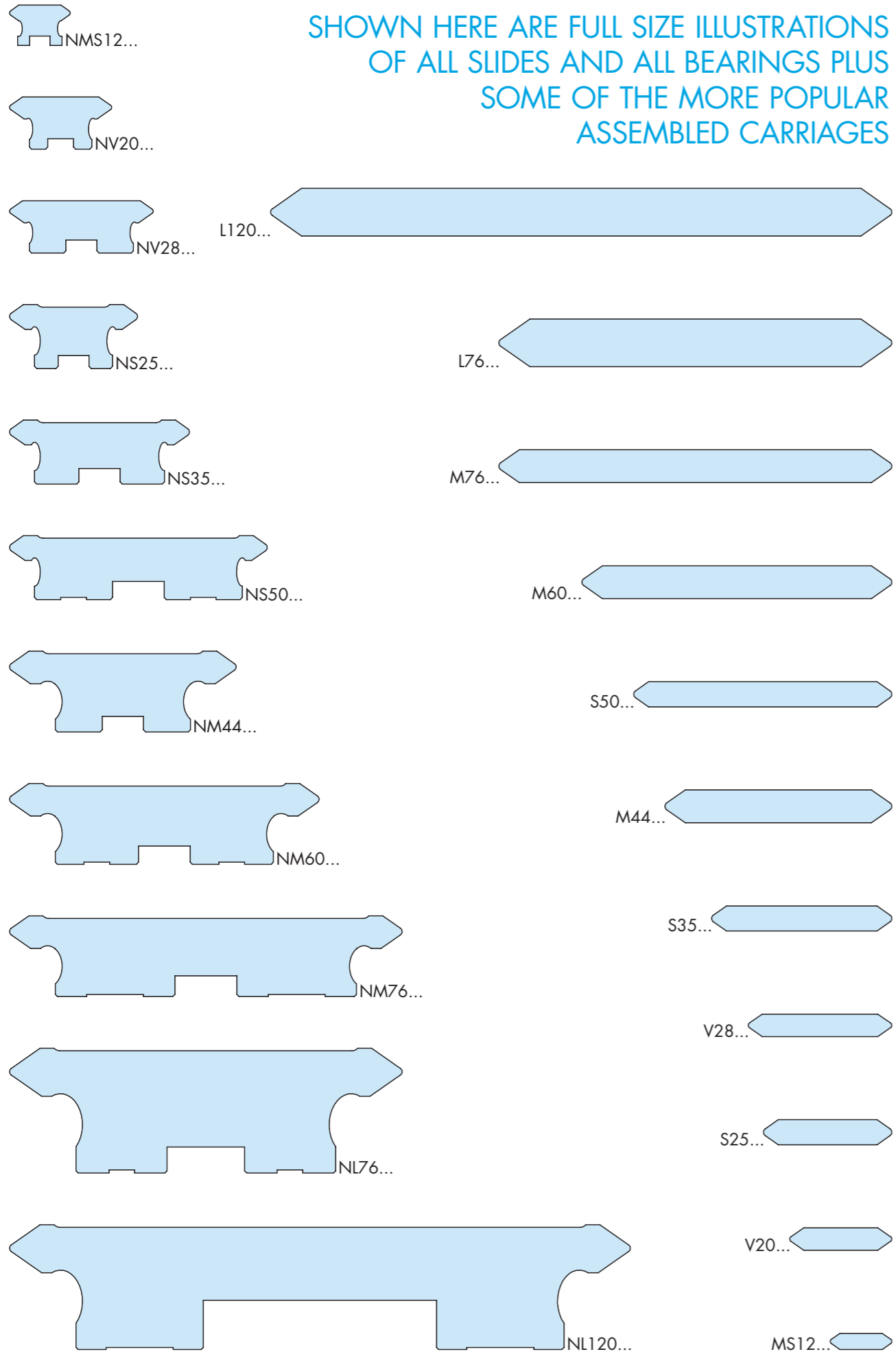

SHOWN HERE ARE FULL SIZE ILLUSTRATIONS OF ALL FLAT TRACKS AND TRACK ROLLERS, WITH ROLLERS RUNNING ON EITHER THE NARROW OR WIDE FACES OF THE TRACK.

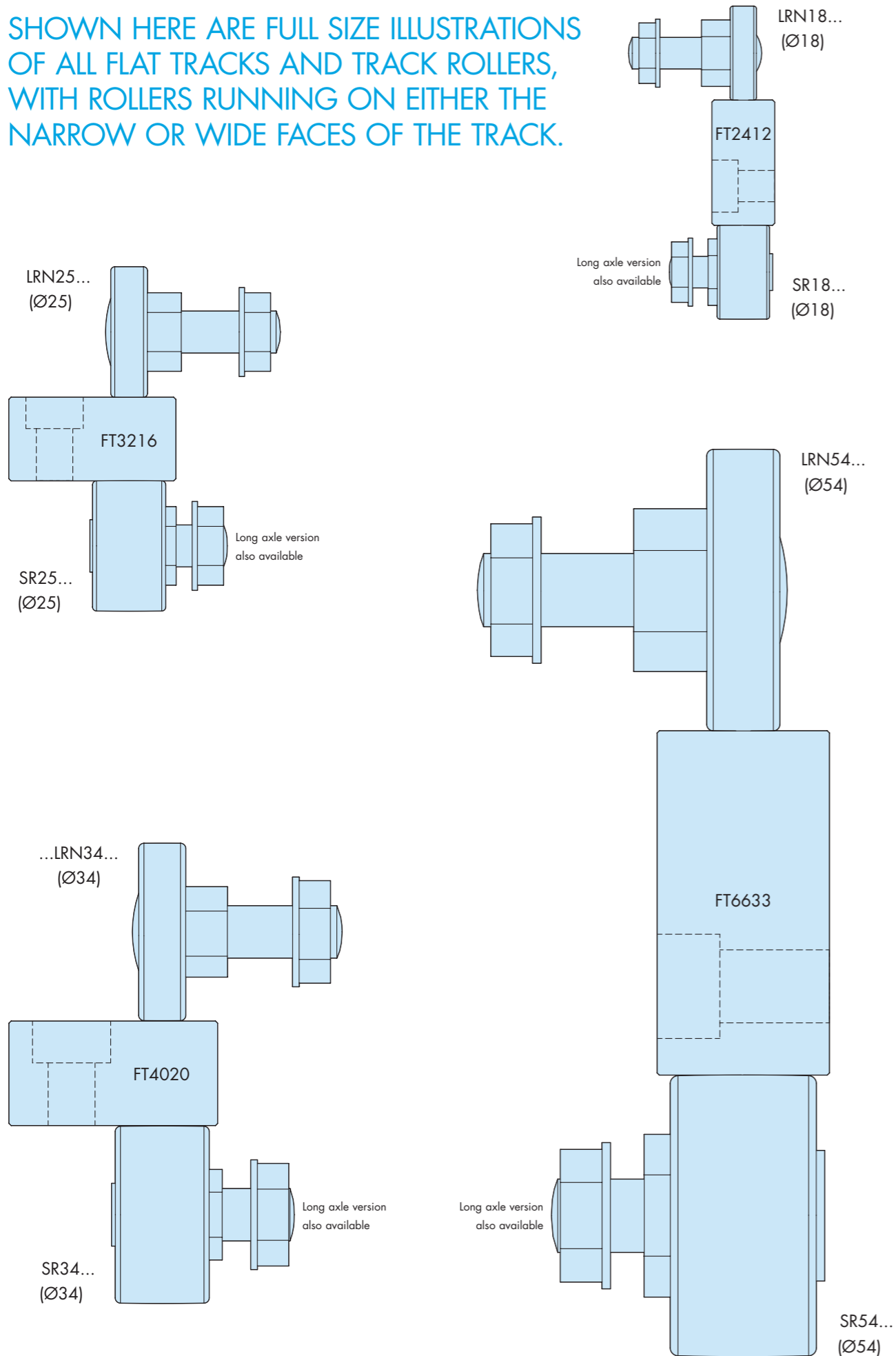

The customer has a wide choice of HepcoMotion GV3 components in order to satisfy most linear motion requirements. To facilitate the selection process, the most commonly used components for a basic Slide System have been tabulated to show comparative benefits when used within a complete system.

The benefits in the table are the important ones, which can be shown in comparative form and are by no means exhaustive. Please see the System Composition section 2-9 and pages relating to the individual components for other features, benefits and variants.

Bearing Type	Load		Speed	Smoothness	Tolerance of Misalignment	Rigidity	System Height	Tolerance of Debris	Price	
	←	←								
Twin Bearing	🟡	🟢	🟡	🟢	🟡	🟢	🟡	🟢	🟡	🟢
Double Row Bearing	🟡	🟢	🟡	🟢	🟡	🟢	🟡	🟢	🟡	🟢
Slimline Bearing	🟡	🟢	🟡	🟢	🟡	🟢	🟡	🟢	🟡	🟢
Floating Bearing	🟡	🟢	🟡	🟢	🟡	🟢	🟡	🟢	🟡	🟢

Slide Precision Grade	▽ = ground surface	General Accuracy		Smoothness /Quietness		Friction		Price	
		🟡	🟢	🟡	🟢	🟡	🟢	🟡	🟢
P1		🟡	🟢	🟡	🟢	🟡	🟢	🟡	🟢
P2		🟡	🟢	🟡	🟢	🟡	🟢	🟡	🟢
P3		🟡	🟢	🟡	🟢	🟡	🟢	🟡	🟢

Lubrication Method	Load		Lubrication Interval		Debris Exclusion		Friction		Safety & Appearance		Price	
	🟡	🟢	🟡	🟢	🟡	🟢	🟡	🟢	🟡	🟢	🟡	🟢
None	🟡	🟢	🟡	🟢	🟡	🟢	🟡	🟢	🟡	🟢	🟡	🟢
Lubricators	🟡	🟢	🟡	🟢	🟡	🟢	🟡	🟢	🟡	🟢	🟡	🟢
Cap Seals or Cap Wipers	🟡	🟢	🟡	🟢	🟡	🟢	🟡	🟢	🟡	🟢	🟡	🟢
Hepco Bleed Lubrication	🟡	🟢	🟡	🟢	🟡	🟢	🟡	🟢	🟡	🟢	🟡	🟢

*The Hepco 'V' Bearing principle has a natural wiping action which tends to expel debris.

The above information is a general guide intended for preliminary selection purposes only.



Bearings (Standard) 34-35



Bearings (Slimline) 36-37



Technical Guide Floating Bearings



Slides 26-31



Lubrication 38-41

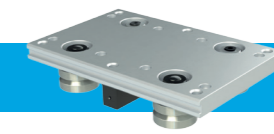

HepcoMotion Standard Carriages are available to suit all sizes of [Double Edge Slides](#), in all grades of precision. Carriage Plates are precision machined from aluminium alloy and are supplied clear anodised.

Carriages may be specified as **Assembled Units (AU Type)**, either factory set to the chosen Slide, or without Slide for self-adjustment.

Removable Carriages incorporate Double Eccentric [Bearings](#), enabling the Carriage to be removed directly from the Slide. For full information and ordering information, please refer solely to the [GV3 Technical Guide](#).

The following types of Bearing and [Lubrication Device](#) may be specified (refer also to the availability table [23](#)).

The Twin Bearing type which is the default choice, comprises two individual Bearings on a common axle. This offers some compliance, smoother running, easy adjustment and greater tolerance of misalignment.

The Double Row Bearing type (DR) incorporates a one piece bearing with two ball tracks. This offers higher load capacity, especially in the radial direction and is less susceptible to entrapment of debris.

Example: Short Carriage with Lubricators on a Flat Slide

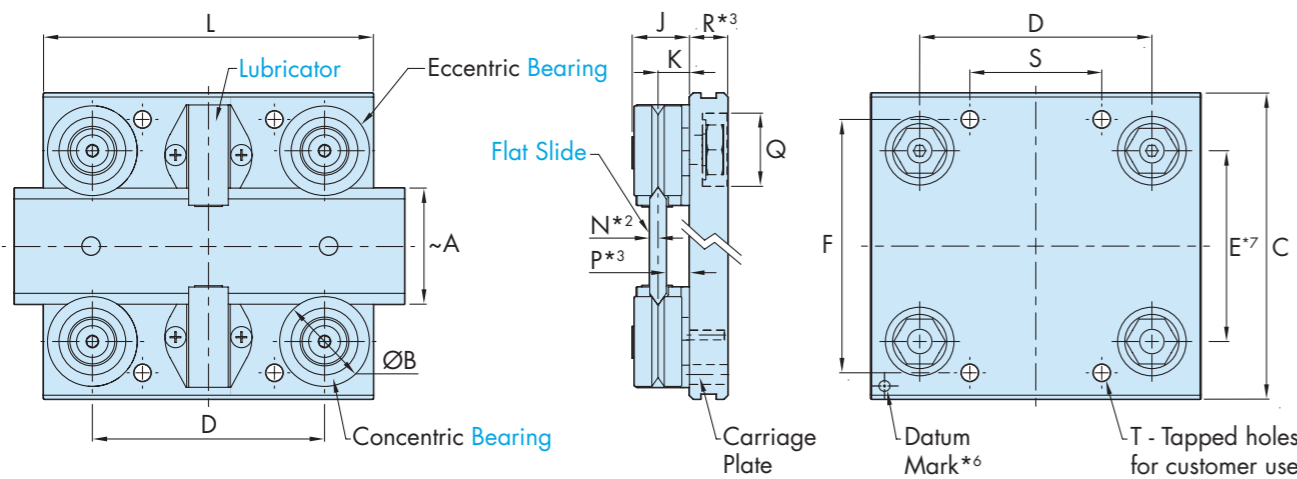

Example: Medium Length Carriage with Cap Seals on a Spacer Slide

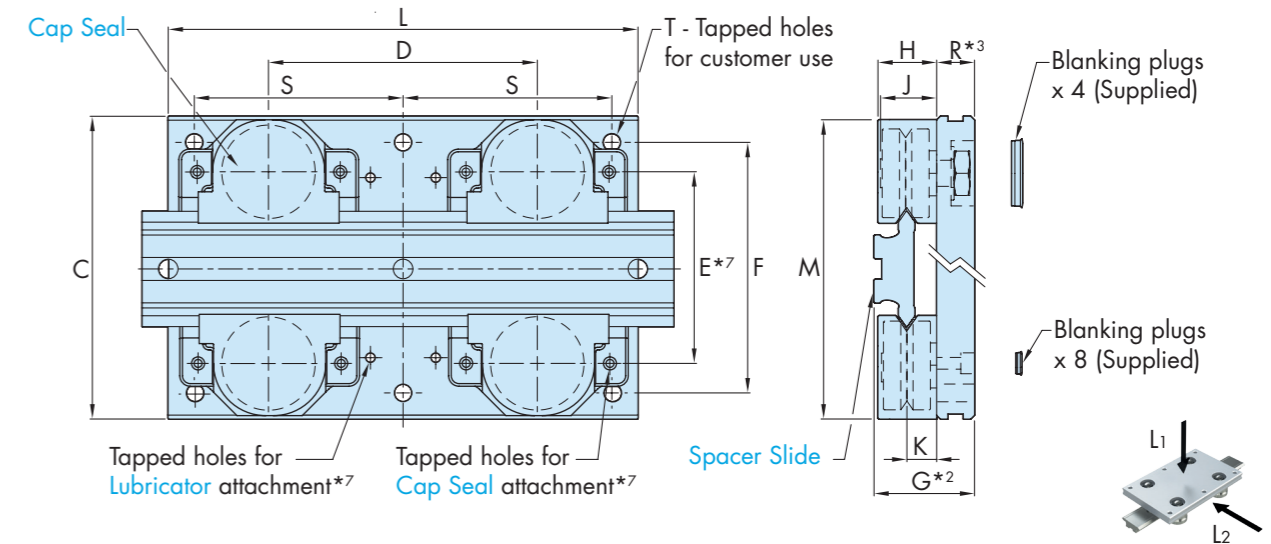

Part Number	Use With		~A	ØB	C	E*7	F	G*2		H	J	K	M	N*2		P*3	Q	R*3	Short Carriage*5				Medium Carriage				Long Carriage				Max Load Capacity (N)*1				
	NMS 12	MS 12						P1	P2 & P3					P1	P2 & P3				L	D	S	T	L	D	S	T	L	D	S	T	DR L1	DR L2	Twin L1	Twin L2	
																																			Ø x depth
AU 12P1/P2 13 ...			12	13	40	22.0	30	19	19.2	-	10.1	5.47	-	1.53	1.6	3.8	12.5 x 4.8	7.34	50	35	17	4 x M4	75	60	25	4 x M4	100	85	50	4 x M4	-	-	240	240	
AU 12P3 13 ...						23.0																													
AU 20 18 ...	NV 20	V 20	20	18	64	34.7	50	24.75	24.95	14	12.4	6.75	57	2.14	2.2	4.5	16 x 7	10	65	43	20	4 x M5	100	55	44	6 x M5	140	95	62	6 x M5	760	1200	500	400	
AU 28 18 ...	NV 28	V 28	28	18	72	42.7	58	25.75	25.95	14	12.4	6.75	65	2.14	2.2	5.5	16 x 8	11	75	52	25	4 x M5	125	80	55	6 x M5	175	130	80	6 x M5	760	1200	500	400	
AU 25 25 ...	NS 25	S 25	25	25	80	46.6	65	30.5	30.7	18	16.6	9	78.5	2.39	2.5	6.5	22 x 8.4	11.5	80	51	24	4 x M6	135	74	60	6 x M6	180	120	82	6 x M6	1600	3000	1280	1200	
AU 35 25 ...	NS 35	S 35	35	25	95	56.6	80	31.5	31.7	18	16.6	9	88.5	2.39	2.5	6.5	22 x 9.4	12.5	100	70	40	4 x M6	150	90	65	6 x M6	200	140	90	6 x M6	1600	3000	1280	1200	
AU 50 25 ...	NS 50	S 50	50	25	112	71.6	95	33	33.2	18	16.6	9	103.5	2.39	2.5	6.5	22 x 10.9	14	110	80	50	4 x M6	160	100	70	6 x M6	220	160	100	6 x M6	1600	3000	1280	1200	
AU 44 34 ...	NM 44	M 44	44	34	116	72.3	96	38.5	38.7	22.5	21.3	11.5	116	3.14	3.2	8.3	25 x 8.7	14.5	125	88	50	4 x M8	180	103	80	6 x M8	225	153	103	6 x M8	3600	6000	3200	2800	
AU 60 34 ...	NM 60	M 60	60	34	135	88.3	115	41	41.2	22.5	21.3	11.5	132	3.14	3.2	8.3	25 x 11	17	150	110	60	4 x M8	200	125	90	6 x M8	280	205	130	6 x M8	3600	6000	3200	2800	
AU 76 34 ...	NM 76	M 76	76	34	150	104.3	130	42	42.2	22.5	21.3	11.5	148	3.14	3.2	8.3	25 x 12.5	18	170	130	80	4 x M8	240	165	110	6 x M8	340	265	160	6 x M8	3600	6000	3200	2800	
AU 76 54 ...	NL 76	L 76	76	54	185	119.1	160	58.5	58.7	36.5	34.7	19	182	4.56	4.7	14.3	32 x 13.5	20	200	140	90	4 x M10	300	198	135	6 x M10	400	298	185	6 x M10	10000	10000	7200	6400	
AU 120 54 ...	NL 120	L 120	120	54	240	163.1	210	62.5	62.7	36.5	34.7	19	226	4.56	4.7	14.3	32 x 17.5	24	240	180	120	4 x M10	360	258	165	6 x M10	480	378	225	6 x M10	10000	10000	7200	6400	

Notes:

- Maximum loads quoted assume lubrication at the interface of [Bearings](#) and [Slide](#). This can best be achieved by using [Cap Seals](#), [Lubricators](#) or the [Bleed Lubrication](#) facility. It is strongly recommended that load and life are determined using the methods shown in the [Load/Life Calculations](#) section. The bearing static and dynamic load capacities (C & Co) often quoted by manufacturers are not the best basis for practical life calculations. C & Co figures are included on the Bearing pages for comparison.
- Some dimensions will vary by the amount of the grinding allowance according to which grade of [Slide](#) is selected. All Carriages are compatible with all grades of Slide with the exception of the smallest (size 12-13). Two sizes of 12-13 Carriages are therefore required: AU 12P1/P2 13, which is suitable for Slide grades P1 & P2, and AU 12P3 13, which is suitable for Slide grade P3.
- Carriage size AU 28 18 incorporates a recess in the underside for fixing screw clearance when used with size V28 [Flat Slide](#). The P dimension in the table includes this recess.
- Controlled Height (CHK) [Bearings](#) are usually selected from stock, quantities available may therefore be restricted. Please see the [GV3 Technical Guide](#).
- [Cap Seals](#) are not available on Short Carriages. [Lubricators](#) may be used for lubrication purposes.
- The datum mark identifies the reference edge used in manufacture. The concentric [Bearings](#) are always mounted on this side.
- [Bearing](#), [Cap Seal](#) and [Lubricator](#) fixing hole sizes and positions are detailed in the [GV3 Technical Guide](#) according to the grade of [Slide](#) used. 'E' is the optimised drilling dimension and is suitable for general purposes. Actual Bearing positions will vary slightly when eccentrically adjusted.

The Nitrile Sealed Bearing option (NS) provides a higher degree of protection against ingress of water or debris in comparison to the default metal shielded type. A small increase in friction may result.

The Controlled Height Bearing option (CHK) minimises variation between Bearings in respect of the important 'K' dimension. This is desirable in high precision applications*4.

The Cap Seal option (CS) ensures efficient lubrication of the 'V' contact surfaces and protects against ingress of debris. Operational safety and system appearance are also improved. Once charged with grease, no further lubrication is necessary under most operating conditions. Lubrication vastly increases load capacity and life.

The Lubricator option (LB) applies oil to the 'V' contact surfaces by means of lightly sprung felt pads which are charged with oil to give long intervals between re-lubrication. The Lubricator option is useful where the advantages of increased load and life are required, but with lower friction compared to the Cap Seal.

See Application Examples on [10](#), [12](#), [14](#), [16](#) & [17](#)

Ordering Details

2 x AU4434 L180 (CS) (DR) (NS) (CHK) + Slide Part Number

Number of Carriages set to specified Slide
 AU... = Assembled Unit
 CP... = Carriage Plate only
 Carriage Length L = 180mm
 Lubrication Options CS for Cap Seals*5 or LB for Lubricators
 Leave blank if not required

Leave blank if Slide is not required and Carriage will be supplied in a loose condition for self-adjustment
 CHK = Controlled Height Bearings*4
 Leave blank for standard tolerance
 NS = Nitrile Sealed Bearings
 Leave blank for metal shielded
 DR = Double Row Bearings
 Leave blank for Twin Bearings

Availability of Carriage Options

Part Number	Twin Bearings	Double Row	Metal Shields	Nitrile Seals	Cap Seal*5	Lubricators	Controlled Height
AU 12...13...	✓	✓	✓	✓	✓	✓	✓
AU 20 18...	✓	✓	✓	✓	✓	✓	✓
AU 28 18...	✓	✓	✓	✓	✓	✓	✓
Larger sizes	✓	✓	✓	✓	✓	✓	✓

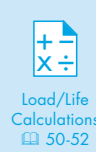

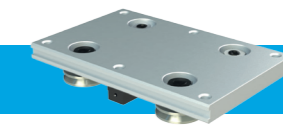

HepcoMotion Slimline Carriages incorporate compact **Slimline Bearings** to minimise system height. They are of lower load capacity compared with **Standard Bearings**, but are lower in cost. Slimline Carriages are available to suit all sizes of **Double Edge Slides**, in all grades of precision. Carriage Plates are precision machined from aluminium alloy and are supplied clear anodised.

Carriages may be specified as **Assembled Units (AU Type)**, either factory set to the chosen **Slide**, or without Slide for self-adjustment.

See Application Example on 12

Example: Short Carriage with Lubricators on a Flat Slide

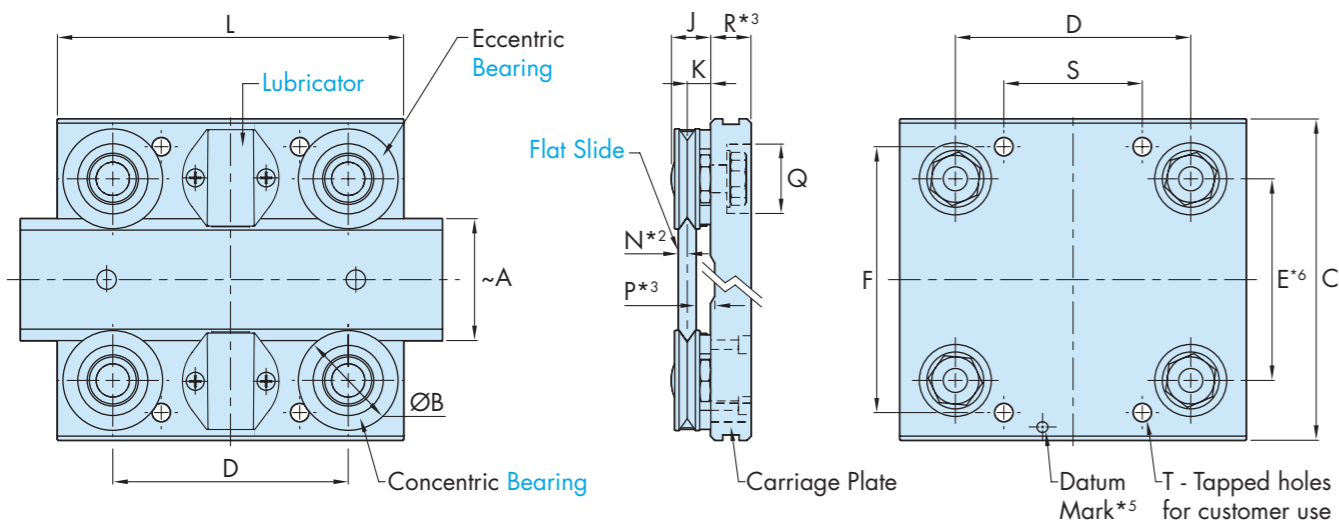

Example: Medium Length Carriage with Cap Wipers on a Spacer Slide

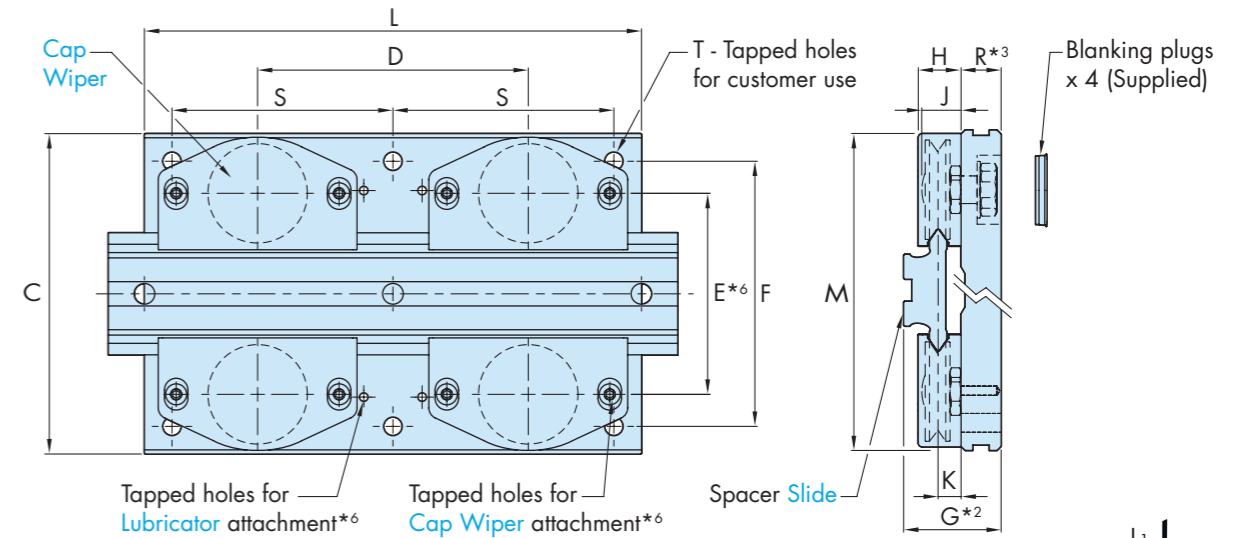

Part Number	Use With		~A	ØB	C	E*6	F	G*2		H	J	K	M	N*2		P*3	Q	R*3	Short Carriage*4				Medium Carriage				Long Carriage				Max Load Capacity (N)*1	
	NV	V						P1	P2 & P3					L	D				S	T	L	D	S	T	L	D	S	T	L1	L2		
	20	20						20	20					20	20				20	20	20	20	20	20	20	20	20	20	20	20	20	20
AU 20 195 ...	NV 20	V 20	20	19.5	64	35.6	50	23.7	23.9	11.2	9.2	5.7	59	2.14	2.2	4.5	16x7	10	65	43	20	4 x M5	100	55	44	6 x M5	140	90	62	6 x M5	400	480
AU 28 195 ...	NV 28	V 28	28	19.5	72	43.6	58	24.7	24.9	11.2	9.2	5.7	67	2.14	2.2	4.5	16x8	11	75	52	25	4 x M5	125	75	55	6 x M5	175	125	80	6 x M5	400	480
AU 25 265 ...	NS 25	S 25	25	26.5	80	46.2	65	28.3	28.5	13	11.3	6.8	76	2.39	2.5	6.5	22x8.4	11.5	85	55	25	4 x M6	135	74	60	6 x M6	180	120	82	6 x M6	940	1150
AU 35 265 ...	NS 35	S 35	35	26.5	95	56.2	80	29.3	29.5	13	11.3	6.8	86	2.39	2.5	6.5	22x9.4	12.5	100	70	40	4 x M6	150	90	65	6 x M6	200	140	90	6 x M6	940	1150
AU 50 265 ...	NS 50	S 50	50	26.5	112	71.2	95	30.8	31	13	11.3	6.8	101	2.39	2.5	6.5	22x10.9	14	110	80	50	4 x M6	160	100	70	6 x M6	220	160	100	6 x M6	940	1150
AU 44 360 ...	NM 44	M 44	44	36	116	72.8	96	35.3	35.5	15.5	14	8.3	113	3.14	3.2	7.9	25x8.7	14.5	125	85	50	4 x M8	180	98	80	6 x M8	225	145	103	6 x M8	2000	2400
AU 60 360 ...	NM 60	M 60	60	36	135	88.8	115	37.8	38	15.5	14	8.3	129	3.14	3.2	7.9	25x11	17	150	108	60	4 x M8	200	120	90	6 x M8	280	200	130	6 x M8	2000	2400
AU 76 360 ...	NM 76	M 76	76	36	150	104.8	130	38.8	39	15.5	14	8.3	145	3.14	3.2	7.9	25x12.5	18	170	128	80	4 x M8	240	160	110	6 x M8	340	260	160	6 x M8	2000	2400
AU 76 580 ...	NL 76	L 76	76	58	195	123.3	170	53.8	54	25	22.8	14.3	186	4.56	4.7	9.6	32x13.5	20	200	135	90	4 x M10	300	190	135	6 x M10	400	290	185	6 x M10	4240	5200
AU 120 580 ...	NL 120	L 120	120	58	240	167.3	210	57.8	58	25	22.8	14.3	230	4.56	4.7	9.6	32x17.5	24	240	185	120	4 x M10	360	240	165	6 x M10	480	360	225	6 x M10	4240	5200

Notes:

- Maximum loads quoted assume lubrication at the interface of **Bearings** and **Slide**. This can best be achieved by using **Cap Wipers**, **Lubricators** or the **Bleed Lubrication** facility. It is strongly recommended that load and life are determined using the methods shown in the **Load/Life Calculations** section. The bearing static and dynamic load capacities (C & Co) often quoted by manufacturers are not the best basis for practical life calculations. C & Co figures are included on the Bearing pages for comparison.
- Some dimensions will vary by the amount of the grinding allowance according to which grade of **Slide** is selected. All Carriages are compatible with all grades of Slide.
- All Carriages except sizes AU 76 580 & AU 120 580 incorporate a recess in the underside for fixing screw clearance when used with **Flat Slides**. The P dimension in the table includes this recess.
- Cap Wipers** are not available on Short Slimline Carriages. **Lubricators** may be used for lubrication purposes. Metal shields are not available for Slimline Carriages AU 20 195 & AU 28 195.
- The datum mark identifies the reference edge used in manufacture. The concentric **Bearings** are always mounted on this side.
- Bearing**, **Cap Wiper** and **Lubricator** fixing hole sizes and positions are detailed in the GV3 Technical Guide [↓](#) according to the grade of **Slide** used. 'E' is the optimised drilling dimension and is suitable for general purposes. Actual Bearing positions will vary slightly when eccentrically adjusted.

Ordering Details

1 x AU44360 L180 (CW) (NS) + Slide Part Number

Number of Carriages set to specified Slide

AU... = Assembled Unit
CP... = Carriage Plate only
Carriage Length L = 180mm

Leave blank if Slide is not required and Carriage will be supplied in a loose condition for self-adjustment

NS = Nitrile Sealed Bearings*4
Leave blank for metal shielded

Lubrication Options
CW for Cap Wipers*4 or LB for Lubricators
Leave blank if not required

Availability of Carriage Options

Part Number	Metal Shields	Nitrile Seals	Cap Wipers*4	Lubricators
AU 20 195...	X	✓	✓	✓
AU 28 195...	X	✓	✓	✓
Larger sizes	✓	✓	✓	✓

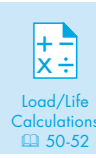

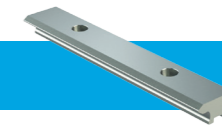

HepcoMotion Single Edge Spacer Slides are available in three precision grades and are manufactured from high quality bearing steel, hardened on the 'V' running faces to provide an extremely hard wearing surface. Other areas remain soft for customising.

Grades P1 & P2 are ground on faces as illustrated. Grade P3 is precision drawn and sufficiently accurate for many applications. See System Selector [21](#).

Slide fixing holes are accurately positioned, enabling customers to pre-drill their mounting holes. Slides without holes are also available.

Spacer Slides bolt directly to the mounting surface of a machine, allowing running clearance for [Bearings](#) and [Lubrication Devices](#). A central keyway is provided for simple location by means of Hepco Dowel Pins or a customer's own key. Alternatively, where Lubrication Devices are not used, the datum edges may be located against a machined register*⁴.

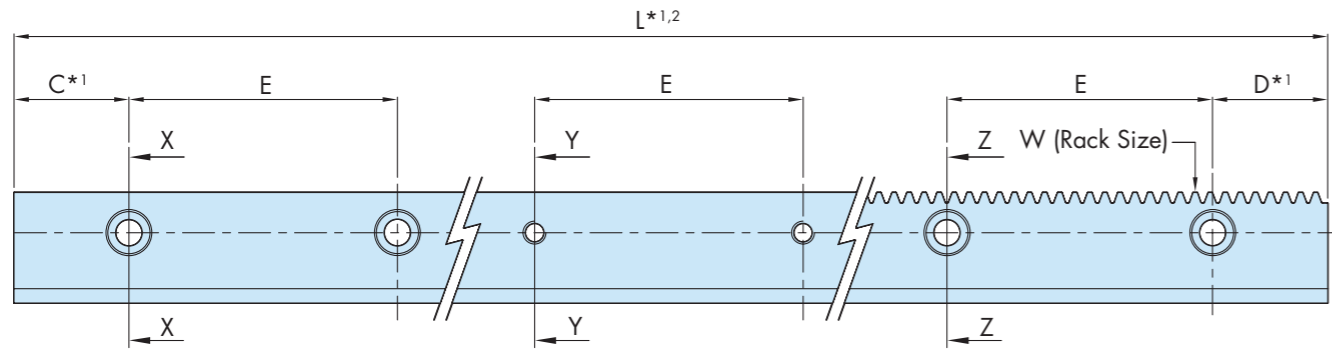

Slide with Counterbored Holes

Slide with Tapped Holes

Rack Cut Slide

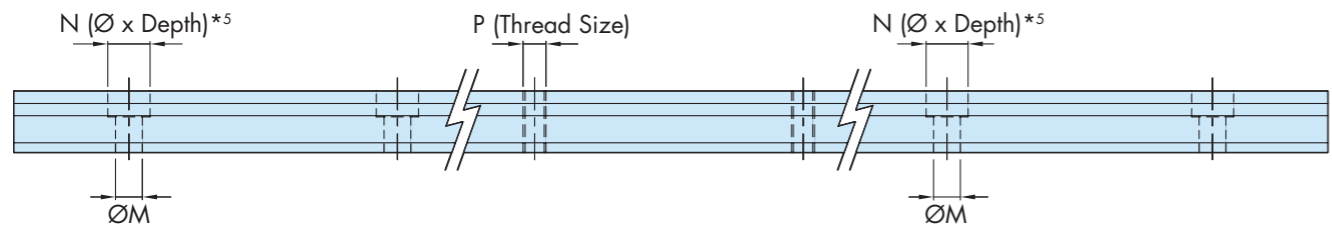

The Single Edge format allows two Slide 'V's to be mounted wide apart resulting in a considerable increase in moment load capacity, stiffness and stability. Spacing Slides apart also provides room for a centrally mounted drive.

Single Edge Spacer Slides are available with a precision rack machined into the back face, providing a convenient and strong means of driving. Corresponding [Pinions](#) are available, including Shaft type versions which are for use in conjunction with the Hepco [Drive Flange](#), [Motors](#) and [Gearboxes](#). Please see the [GV3 Technical Guide](#) [↓](#).

The large rear face of the Single Edge Spacer Slide, although unhardened, is sufficiently durable to act as a track on which to run Hepco [Track Rollers](#).

See Application Examples on [15](#), [16](#) & [17](#)

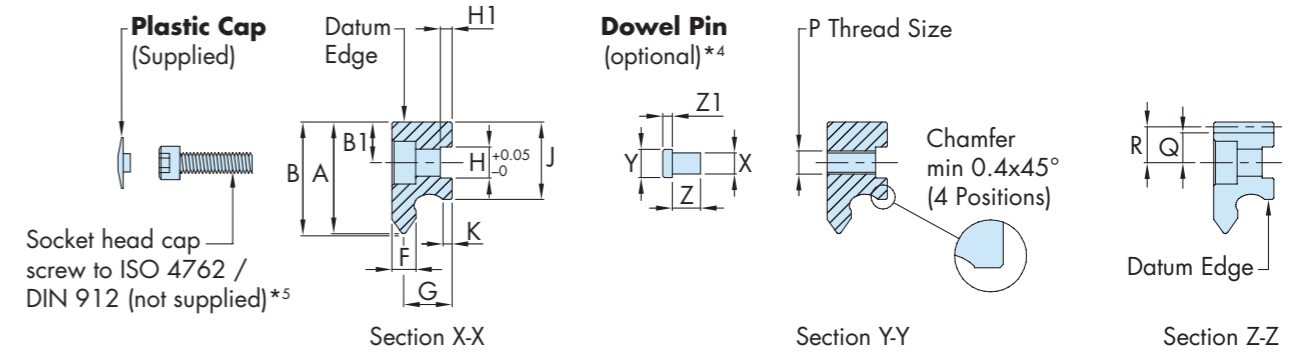

Available Grades of Slide

✓ Indicates surfaces which are precision ground

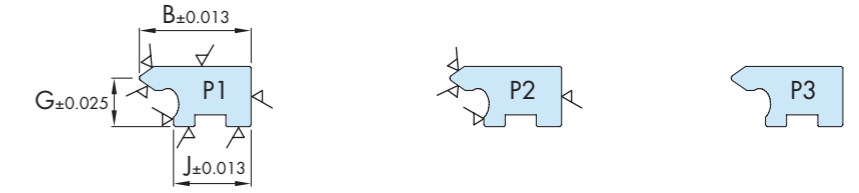

Part Number	Use With* ³		A ~ Slide Width	B		B1		C & D* ¹	E	F		G		H	H1	J	K	L max* ^{1,2}		M	N* ⁵	P	Q	R	W Mod	Dowel Pin	X K6	Y m6	Z	Z1	Max Rack Force lubricated (N)	
		P1 & P2	P3	P1 & P2	P3			P1	P2 & P3	P1	P2 & P3					P1 & P2	P3													
																														
NMS E J 13 ...	-	11	11.19	11.71	5	5.3	20.5	45	3.0	3.2	6.2	6.4	4	1.8	9.25	9.65	1.7	1976	4046	3.5	6.2 x 3.1	M3	3.80	4.5	0.5	SDP4	4	4	6.75	-	180
NV E J 18 J 195 ...	16	16.19	16.72	6.5	6.7	43	90	4.21	4.42	8	8.2	4	1.5	12	12.4	1.75	4046	4046	4.5	8 x 4.1	M4	4.82	5.8	0.7	SDP4	4	4	6.75	-	300
NS E J 25 J 265 ...	21	21.37	21.89	8.5	8.7	43	90	4.71	4.93	10	10.2	6	2.5	16	16.4	2.6	4046	4046	5.5	10 x 5.1	M5	6.15	7.4	1	SDP6	4	6	6	2.25	500
NM E J 34 J 360 ...	29	29.37	29.89	10.5	10.7	43	90	6.21	6.42	12.5	12.7	8	3	20	20.4	2.3	4046	4046	7	11 x 6.2	M6	7.69	9.25	1.25	SDP8	6	8	8	2.75	1000
NL E J 54 J 580 ...	43	43.37	43.89	16	16.2	88	180	9.21	9.43	19.5	19.7	12	4	30	30.4	4.8	4046	4046	11	18 x 10	M10	11.6	14.1	2	SDP12	10	12	15	3.75	1600

Notes:

- Any length of Slide within L max dimension can be supplied, but for optimum price and delivery time, Slide lengths should be specified which maintain the C and D dimensions in the table above (n x hole pitch E + C + D, where n equals the number of hole pitches). In all cases, unless otherwise specified by the customer, C and D dimensions will be supplied equal. The position of the teeth on the rack cut versions relative to the mounting holes or Slide ends, will vary. Rack cut Slides with a regulated tooth position can be supplied on request.
- Where Slides longer than the maximum length are required, lengths can be matched, suitable for butting. Some sizes of Rack cut Slides are not always stocked in maximum lengths. In such cases the customer will be offered matched lengths for butting.
- In the table, the preferred choices of [Bearings](#) to use with each Slide are quoted. However, other combinations are possible (please see 'Mix & Match' Component Compatibility in the [GV3 Technical Guide](#) [↓](#)).
- Slides in their free unmounted state are not necessarily absolutely straight. If straightness is important, the Slide may be set by bolting down against a register. If Hepco Dowel Pins are used, these should be positioned one each end centrally between the Slide end and first hole and one located centrally between each pair of fixing holes, or as deemed necessary for the application.
- For the rack cut version of Slide size NVE, the counterbore diameter 'N' has been reduced slightly to suit cap head screws ISO 4762 / DIN 912 without knurled head. This is to maximise the strength in the critical area between the counterbore and root of the rack teeth. Due to accuracy requirements, pre-drilling of fixing holes is not recommended. Screws are available from Hepco: Part No. PFS415 (M4 x 15 long).

Ordering Details

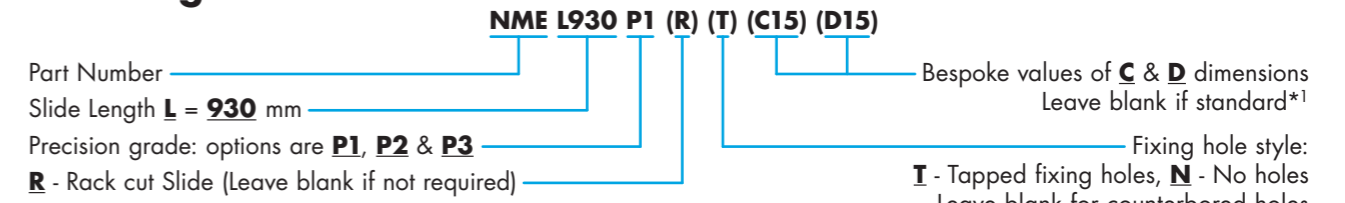

Ordering Example:

1 x NSE L2066 P3 N — Single Edge Spacer Slide in precision grade 3, 2066 mm long with no holes
 24 x SDP6 — 6 mm Ø head dowel pins (optional)

CAD

Technical Guide [↓](#)

Assembled Systems

System Selector [21](#)

Bearings [34-37](#)

Load/Life Calculations [50-52](#)

Lubrication [38-41](#)

Gearboxes, Motors & Drive Flanges [49](#)

Pinions [47](#)

Track Rollers [43-45](#)

Technical Guide [↓](#)

Mix & Match Options

Technical Guide [↓](#)

Component Mass

HepcoMotion Double Edge Flat Slides and Single Edge Flat Slides are available in three precision grades*4. They are manufactured from high quality bearing steel and hardened on the 'V' running faces to provide an extremely hard wearing surface. Other areas remain soft for customising.

Grades P1 & P2 are ground on faces as illustrated. Grade P3 is precision drawn and is sufficiently accurate for many applications. See System Selector [21](#).

Slide fixing holes are accurately positioned enabling customers to pre-drill their mounting holes. Slides without holes are available in the unground P3 version. The counterbored hole version accommodates low head cap screws to achieve a flush top surface*5.

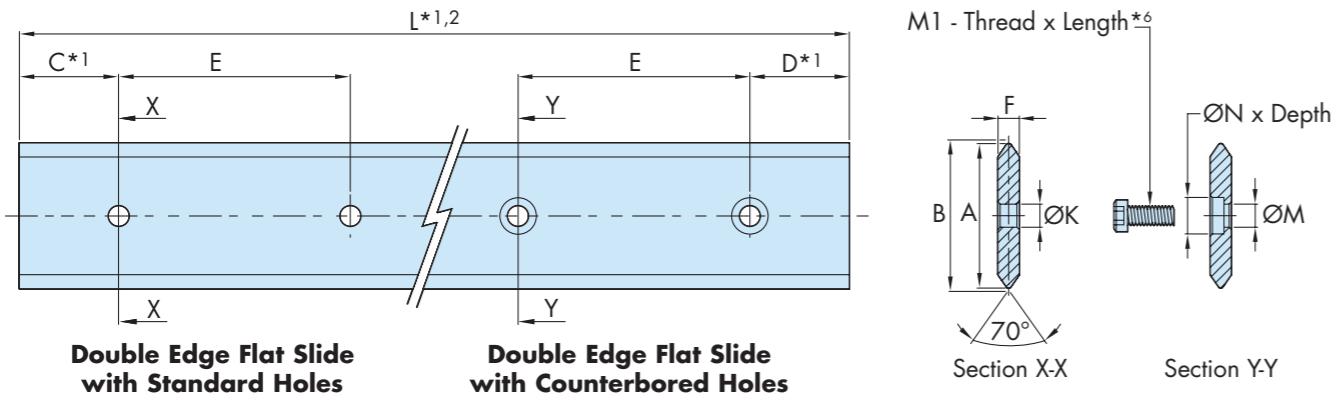

Flat Slides are useful if weight saving or minimum inertia is required, where the Slide is the moving component, and also where it is practical and cost advantageous to design a support profile integral with the machine, to provide running clearance for the [Bearings](#) and [Lubrication Devices](#).

The Single Edge format allows two Slide 'V's to be mounted wide apart resulting in a considerable increase in moment load capacity, stiffness and stability. Spacing Slides apart can also allow room for a centrally mounted drive.

See Application Examples on [10](#), [11](#), [13](#), [14](#) & [15](#)

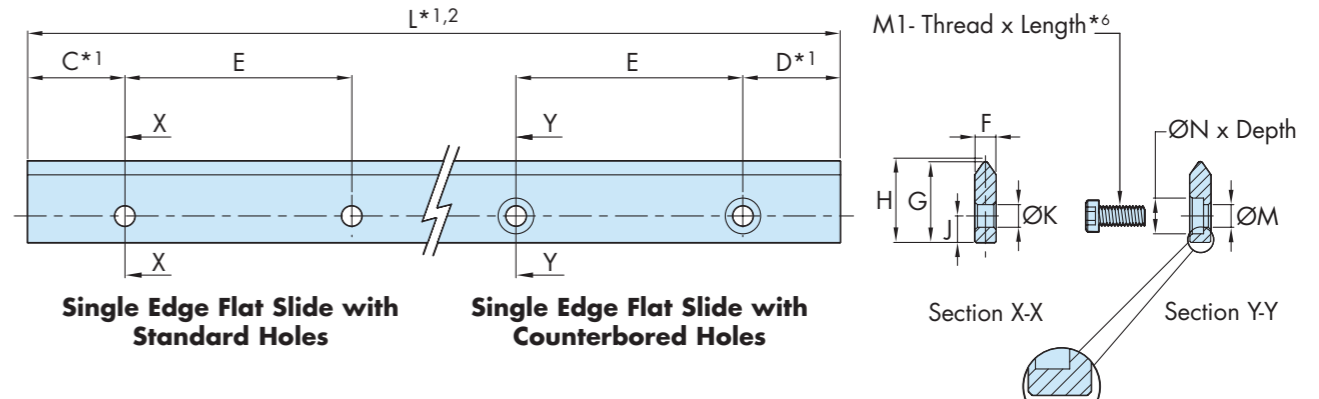

Available Grades of Slide

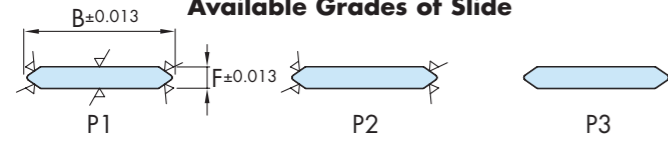

✓ Indicates surfaces which are precision ground

The L120 section has 2 rows of holes

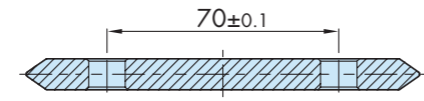

The L120 section has 2 rows of holes

Available Grades of Slide

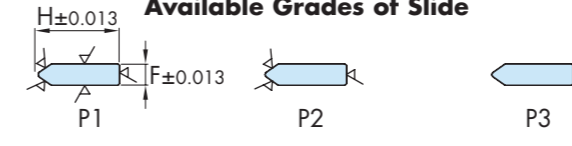

✓ Indicates surfaces which are precision ground

Chamfer min. 0.4 x 45°
2 positions

Part Number	Use With ³	A	B		C & D*1	E	F		G	H			J		K		L max ^{1,2}		M	M1*6		N
			~Slide Width	P1 & P2			P3	±0.2		P1	P2 & P3	~Slide Width	P1 & P2	P3	P1 & P2	P3	Ø	Screw Size		P1 & P2	P3	
MS 12 ...	MS E ...	12	12.55	13.13	13	30	3.05	3.2	-	-	-	-	-	-	3.5	M3	1000	1976	-	-	-	-
V 20 ...	V E ...	20	20.37	21.01	20.5	45	4.27	4.42	11	11.37	11.8	4.5	4.7	-	4.5	M4	4046	4046	4.5	M4 x 10	FS410	8 x 2.8
V 28 ...	V E ...	28	28.37	29.01	43	90	4.27	4.42	16	16.37	16.8	6.0	6.2	-	5.5	M5	4046	4046	4.5	M4 x 10	FS410	8 x 2.8
S 25 ...	S E ...	25	25.81	26.58	43	90	4.78	4.93	-	-	-	-	-	7	M6	4046	4046	5.5	M5 x 10	FS510	10 x 3.5	
S 35 ...	S E ...	35	35.81	36.58	43	90	4.78	4.93	-	-	-	-	-	7	M6	4046	4046	5.5	M5 x 10	FS510	10 x 3.5	
S 50 ...	S E ...	50	50.82	51.58	43	90	4.78	4.93	19	19.46	20.0	6.5	6.7	-	5.5	M5	4046	4046	5.5	M5 x 10	FS510	10 x 3.5
M 44 ...	M E ...	44	44.81	45.58	43	90	6.28	6.42	-	-	-	-	-	7	M6	4046	4046	7	M6 x 12	FS612	11 x 4	
M 60 ...	M E ...	60	60.81	61.58	43	90	6.12	6.42	-	-	-	-	-	9	M8	4046	4046	7	M6 x 12	FS612	11 x 4	
M 76 ...	M E ...	76	76.81	77.58	43	90	6.28	6.42	25	25.46	26.0	8.0	8.2	-	7	M6	4046	4046	7	M6 x 12	FS612	11 x 4
L 76 ...	L E ...	76	76.81	77.58	43	90	9.12	9.43	-	-	-	-	-	11.5	M10	4046	4046	11.5	M10 x 20	FS1020	18 x 6	
L 120 ...	L E ...	120	120.81	121.58	88	180	9.12	9.43	32	32.46	33.0	10.0	10.2	-	9	M8	4046	4046	9	M8 x 20	FS820	15 x 6

Notes:

- Any length of Slide within L max dimension can be supplied, but for optimum price and delivery time, Slide lengths should be specified which maintain the C and D dimensions in the table above (n x hole pitch E + C + D, where n equals the number of hole pitches). In all cases, unless otherwise specified by the customer, C and D dimensions will be supplied equal.
- Where Slides longer than the maximum length are required, lengths can be matched, suitable for butting.
- In the table, the preferred choices of [Bearings](#) to use with each Slide are quoted. However, other combinations are possible (please see 'Mix & Match' Component Compatibility in the GV3 Technical Guide [↓](#)).
- Slides in their free unmounted state are not necessarily absolutely straight. If important, the Slide should be bolted down to a flat surface and set straight.
- A flush top surface is necessary where a belt is to be run on the top surface of the Slide, or in cases where there is restricted room between Slide and Carriage plate as may happen if mixing and matching between Slide and Bearing sizes. Also if using Slimline Bearings.
- Low head socket cap screws DIN 6912 are not universally stocked but are available from Hepco in a single length for each thread size (see table).

Ordering Details

Part Number **M60 L930 P1 (C) (C15) (D15)**

Slide Length **L = 930 mm**

Precision grade: options are **P1, P2 & P3**

Bespoke values of **C & D** dimensions in mm. Leave blank if standard*1

Fixing hole style: **C** - Counterbored holes (Not available on MS12 & MSE) **N** - No holes (P3 grade only) Leave blank for plain holes

Ordering Example:
 1 x LE L2156 P3 C — Single Edge Flat Slide x 2156 mm long in unground grade 3 with counterbored holes
 24 x FS820 — Low head socket cap screws M8 thread x 20mm long (optional)

CAD

Technical Guide [↓](#)

Assembled Systems

Bearings [34-37](#)

Load/Life Calculations [50-52](#)

Carriages [22-25](#)

Technical Guide [↓](#)

Belt Driven Carriages

Rack Driven Carriages [48](#)

Spacer Slides [26-29](#)

Lubrication [38-41](#)

Technical Guide [↓](#)

Mix & Match Options

Technical Guide [↓](#)

Component Mass

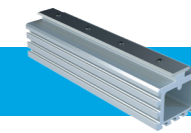

HepcoMotion Slide Beams consist of a Flat Slide mounted onto a precision, anodised aluminium extrusion to provide a rigid self supporting beam, which can form an integral part of a machine structure. See GV3 Technical Guide for Slide & Slide Beam deflection calculations. There are three basic sizes of beam, each available with a number of Slide widths. The smaller size beam is also available as a lightweight version. SB S... and SB M... Slide Beams can be supplied in lengths of up to 8 metres, while SB L... Slide Beams can be supplied in lengths of up to 6 metres*1,3. Slides are available in a choice of three precision grades, as illustrated.

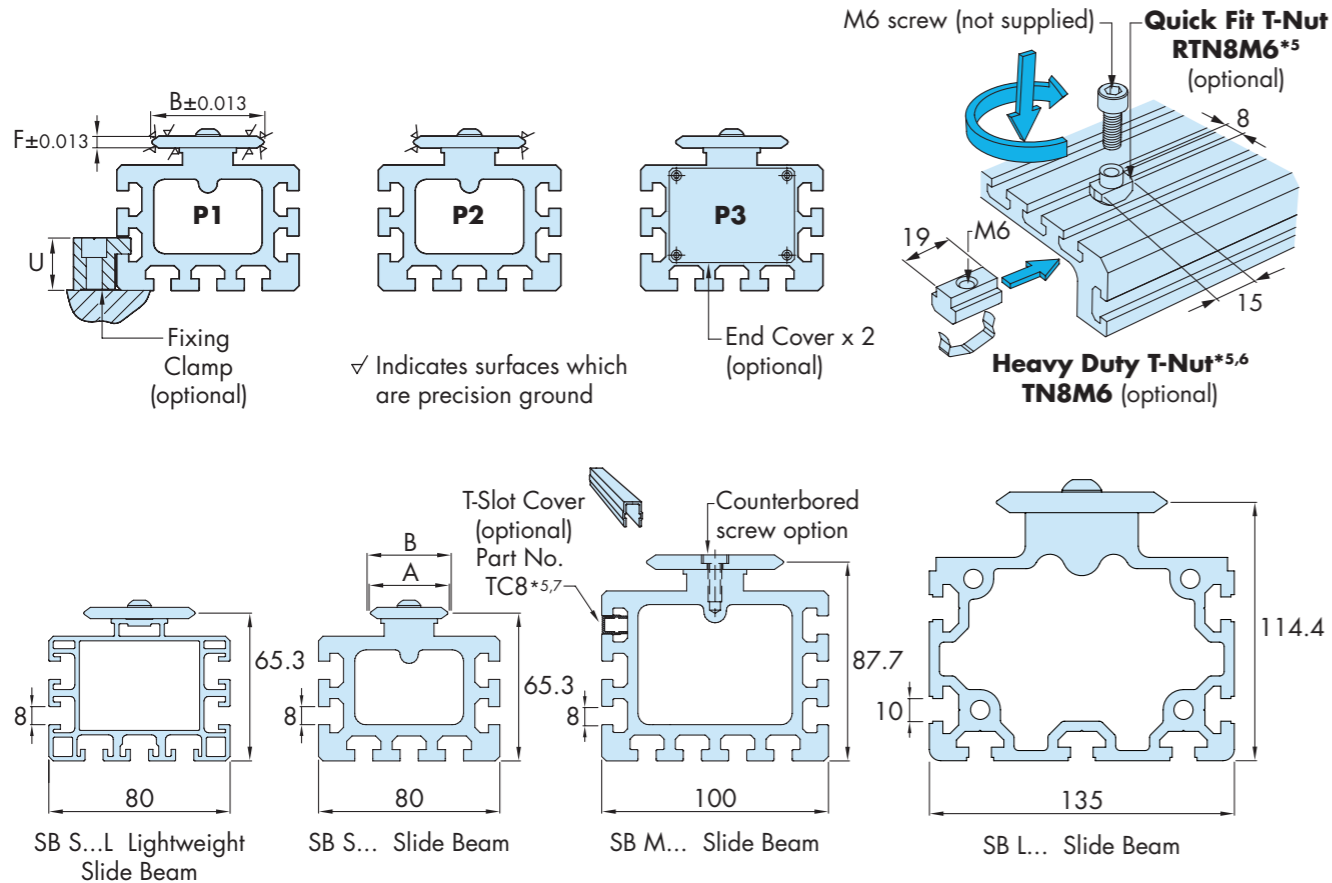

The counterbored Slide option is necessary if Slide Beams are to be used in conjunction with Belt Driven Carriages. This is to provide an uninterrupted path for the belt. Please see the GV3 Technical Guide. Customers requiring a complete ready-to-install belt driven unit with pulleys and optional motor may wish to consider the HepcoMotion Driven Linear System product range.

See Application Examples on 14

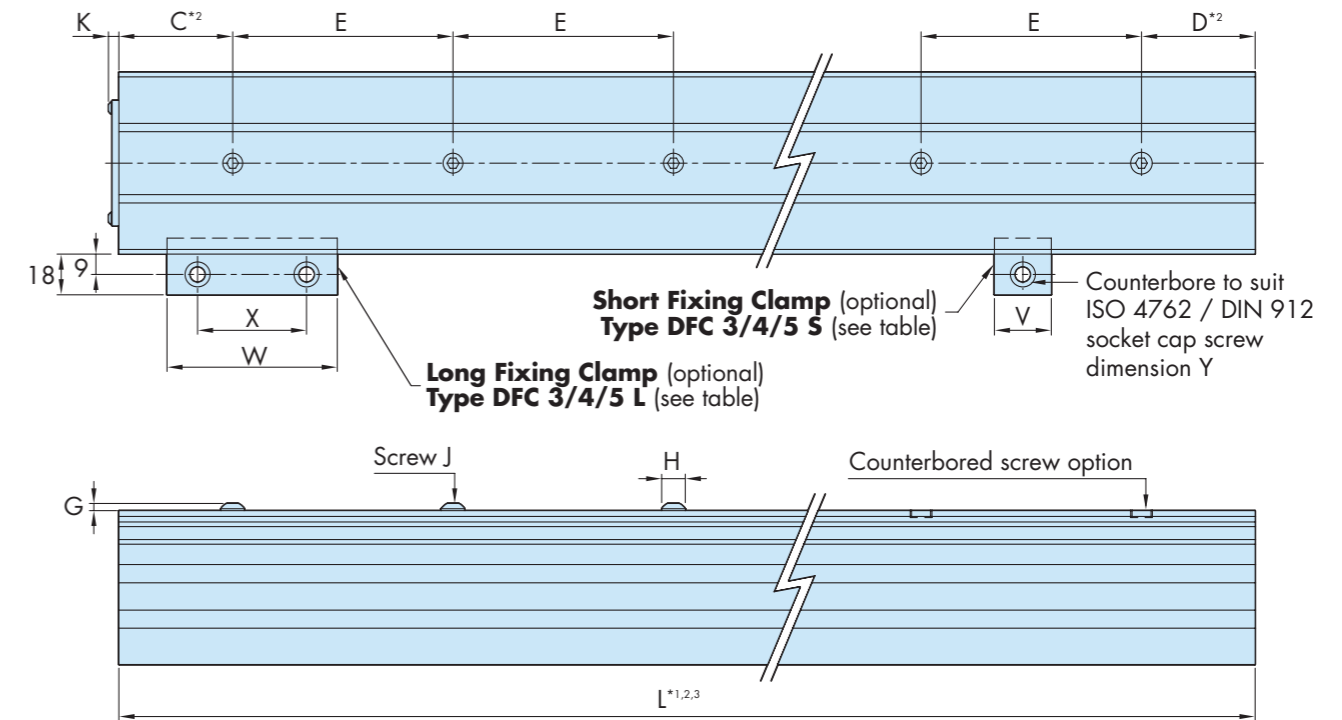

Part Number	Use With Carriages*4			A	B		C & D*2	E	F	G	H	J		K	L max *1,2,3	Fixing Clamp		T-Nut		T-Slot Cover	U	V	W	X	Y	
	Standard	Slimline	Belt Driven		P1 & P2	P3						Standard	C/bored			Short	Long	Quick Fit	Heavy Duty							
SB S 35 ...	AU 35 25 ...	AU 35 265 ...	AU BD 35 25 ...	35	35.81	36.58	43	90	4.78	4.93	3.3	10.5	M6	M5	5.5	8000	DFC3S	DFC3L	RTN8M6	TN8M6	TC8	23	25	75	48	M6
SB S 50 ...	AU 50 25 ...	AU 50 265 ...	AU BD 50 25 ...	50	50.82	51.58																				
SB M 44 ...	AU 44 34 ...	AU 44 360 ...	AU BD 44 34 ...	44	44.81	45.58	43	90	6.28	6.42	3.3	10.5	M6	M6	5.5	8000	DFC4S	DFC4L	RTN8M6	TN8M6	TC8	23	25	100	65	M8
SB M 60 ...	AU 60 34 ...	AU 60 360 ...	AU BD 60 34 ...	60	60.81	61.58																				
SB M 76 ...	AU 76 34 ...	AU 76 360 ...	AU BD 76 34 ...	76	76.81	77.58																				
SB L 76 ...	AU 76 54 ...	AU 76 580 ...	Unavailable	76	76.81	77.58	43	90	9.12	9.43	5.5	17.5	M10	M10	10.5	6000	DFC5S	DFC5L	See Note 5 for details.		25.5	35	140	100	M10	

Notes:

- Beams longer than 4046mm are supplied with two or more lengths of matched Slide, each mounted and dowelled to form a precision joint. Additional fixing screws are normally provided adjacent to each joint. Slide Beams with shorter Slides fixed in any position, can be supplied upon request.
- For optimum price and delivery time, Slide Beam lengths should be specified which maintain the C and D dimensions in the table above. In all cases, unless otherwise specified by the customer, C and D dimensions will be supplied equal.
- For requirements in excess of L max, Slide Beams can be supplied matched ready for joining. Please contact Hepco for details.
- In the table, the available choices of Carriage to use with each Slide Beam are quoted. However, it is possible to use a customer made carriage incorporating other sizes of Bearing. Please see details of "Mix & Match" possibilities in the GV3 Technical Guide.
- Quick Fit T-Nut RTN8M6, Heavy Duty T-Nut TN8M6 and T-Slot Cover TC8 are compatible with SB S... and SB M... types only. Type SB L... Slide Beams are compatible with all MCS Machine Construction System Slot 10 T-Nuts, Slot Blocks and T-Slot Covers.
- The Heavy Duty T-Nut TN8M6 is recommended for the lightweight beam and where greater security of fixing is required. T-Nut section is also available for Type SB S... and Type SB M... Slide Beams, in undrilled lengths up to 1000mm. Please specify part number TN8S followed by the required length in mm. For information on T-Nut section options for Type SB L... Slide Beams, please contact Hepco.
- T-Slot Cover TC8 is made from black UPVC and is available in lengths up to 8000mm. Please specify part number TC8 followed by the required length in mm.

Ordering Details

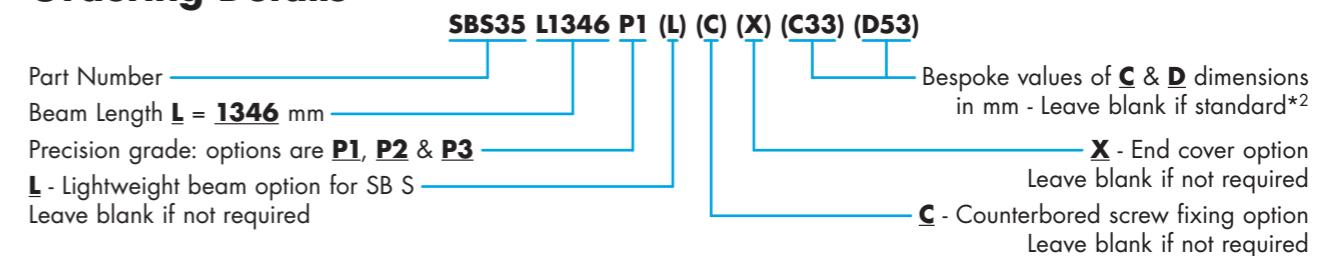

Ancillary Items:

See table for the part numbers relating to T-Nuts*6, T-Slot Cover *5,7 and Fixing Clamps.

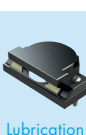
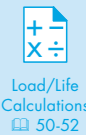

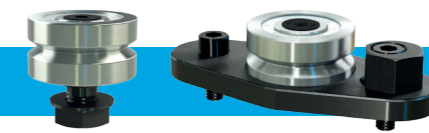

HepcoMotion Standard Bearings are designed to be used with particular sizes of Slide but may be "Mix & Matched" in many instances*6.

The following Bearing formats and fixing methods are available:

The Twin Bearing type, which is the default choice, comprises of two individual deep groove ball bearings on a single axle. This construction offers some compliance, allowing smoother running, easy adjustment and greater tolerance of misalignment.

The Double Row Bearing type (DR) incorporates a one-piece bearing with two ball tracks. This offers higher load capacity, especially in the radial direction and is less susceptible to entrapment of debris.

Both types of Bearing have been designed specially for Slide System applications and their performance confirmed by rigorous testing. External dimensions are identical.

The Nitrile Sealed option (NS) provides a higher degree of protection against ingress of water or debris in comparison to the default metal shielded type. A small increase in friction may result.

Through Fixing Type (SJ/LJ)

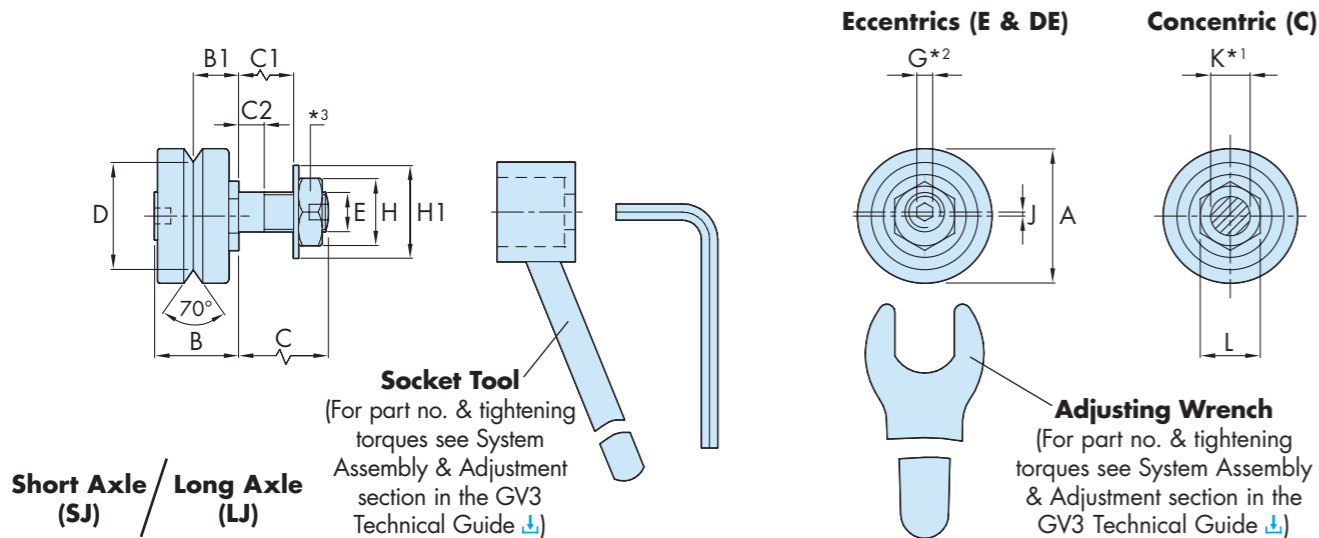

Part Number	Use With*6	A	B	B1	C		C1 max		C2		D ±0.025	E Metric Fine	F	G*2	H	H1	J		K*1	L	M	N	P	P1	Q	Q1	Q2	R ±0.1	R1	S	T	U	V
					Short Axle	Long Axle	Short Axle	Long Axle	Short Axle	Long Axle							...E...	...DE...															
... J 13 ...	NMS & MS	12.7	10.1	5.47	5.8	9.5	3	6.7	2.2	2.4	9.51	M4x0.5	8	-	7	9	0.5	1.9	4	7	5.8	1.0	6.25	6.6	8.5	3.75	6.75	30	47.5	8	20	M3	5.5
... J 18 ...	NV & V	18	12.4	6.75	7.4	14	3.4	10	2.4	2.5	14.0	M6x0.75	10	2.5	10	13	0.7	2.6	6	11	7.4	1.2	8	10.5	10	4	8	38	54	11	24.5	M4	7
... J 25 ...	NS & S	25	16.6	9	9.8	19	3.8	13	3.4	4.9	20.27	M8x1	14	3	13	17	0.75	2.75	8	13	9.8	1.5	7	9	12	5	10	50	72	14	32	M5	8.5
... J 34 ...	NM & M	34	21.3	11.5	13.8	22	6.6	14.8	5.2	5.9	27.13	M10x1.25	18	4	17	21	1	3.6	10	15	13.8	2.0	9.5	8.5	17.5	6.5	12.5	60	90.5	17	42	M6	10
... J 54 ...	NL & L	54	34.7	19	17.8	30	8.2	20.4	5.7	7.9	41.76	M14x1.5	28	6	22	28	1.5	5.5	14	27	17.8	3.0	14.5	16.4	23.5	10.5	18.5	89.5	133	25	62	M8	13

Part Number	Max Working Load Capacity (N)		Bearing Static (Co) and Dynamic (C) Load Capacity (N)*5										
	Double Row Bearings		Twin Bearings		For Double Row Bearings				For each Twin Bearing race				
	Radial	Axial	Radial	Axial	Radial Loads		Axial Loads		Radial Loads		Axial Loads		
				Co	C	Co	C	Co	C	Co	C	Co	C
... J 13 ...	-	-	120	60	-	-	-	-	265	695	74	194	
... J 18 ...	600	190	200	125	1168	2301	435	857	593	1438	173	419	
... J 25 ...	1500	400	600	320	2646	5214	821	1618	1333	3237	326	791	
... J 34 ...	3000	900	1400	800	5018	9293	1362	2523	2600	5291	557	1270	
... J 54 ...	5000	2500	3200	1800	12899	21373	2777	4601	6657	13595	1136	2320	

- Notes:**
- It is recommended that holes to suit Bearing mounting axles should be reamed to tolerance F6 for a sliding fit.
 - All eccentric Through Fixing type Bearing axles are supplied with sockets for adjustment as shown, with the exception of size 13.
 - Nuts for the Through Fixing type Bearings are chemically blacked on the concentric version and bright zinc plated on the eccentrics for identification purposes.
 - Controlled Height (CHK) Bearings are usually selected from stock, quantities available may therefore be restricted. Please see the GV3 Technical Guide.
 - The quoted static and dynamic load capacities are based on industry standard calculations. These do not accurately reflect system performance, and are only provided for comparison with other systems. Please use the Max Working Load figures and the Load/Life Calculations section to determine system performance.
 - The preferred choices of Slide to use with each Bearing are quoted. Other Slides may be used, as shown in the 'Mix & Match' Component Compatibility section of the GV3 Technical Guide.
 - The Blind Hole Eccentric Bearings cannot be fitted with Cap Seals, however Slide Lubricators may be specified instead.

The Through Hole Fixing type is available in two axle lengths, with the short axle version being compatible with Standard Carriage Plates. Both versions are available as fixed position Concentric type (C), adjustable Eccentric type (E), and Double Eccentric type (DE), which allows a Removable Carriage to be disengaged from a Slide.

All Bearings are available in a Controlled Height version (CHK) which minimises variation in the B1 dimension*4. This is desirable in high precision applications.

The Blind Hole Fixing type (BHJ) allows mounting into a solid machine base where through mounting is not possible, or where adjustment from the front is preferred. They are available in Concentric type (C), which are fixed, and Eccentric type (E), which are adjustable.

All Bearings are greased for life internally. Customers are strongly recommended to provide lubrication to the interface between Bearings and Slide by specifying Hepco Cap Seals*7, which fit over the Bearings, or by using Hepco Lubricators. Lubrication greatly increases load capacity and life.

See Application Examples on 10 - 17

Blind Hole Fixing Type (BHJ)

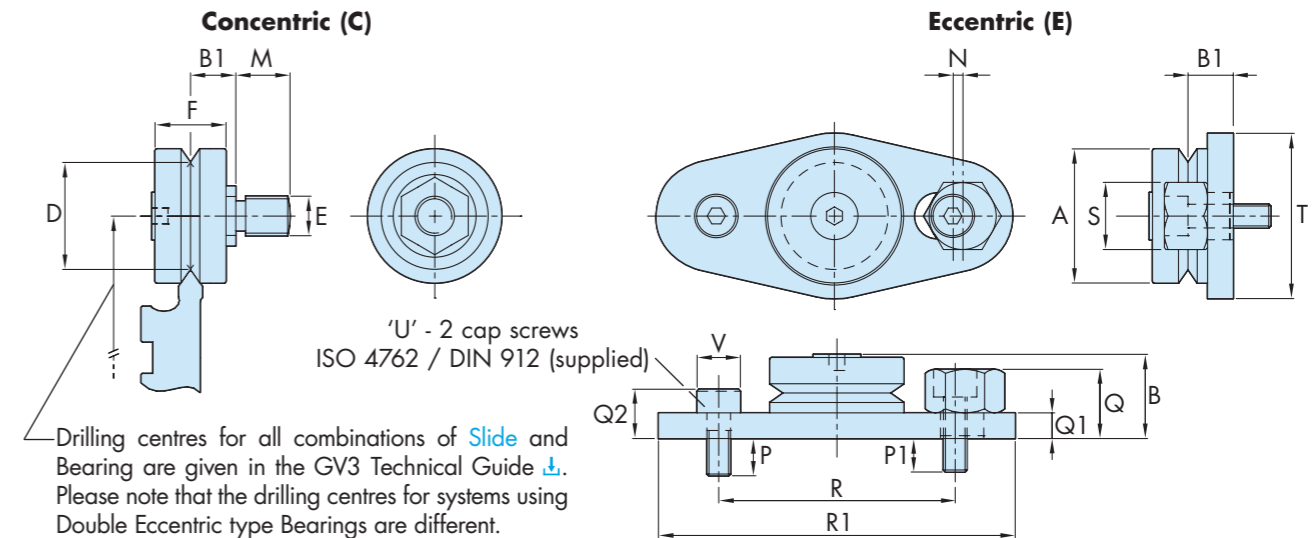

A range of Bearing Lubricators are available as an alternative to Cap Seals and Slide Lubricators. Please refer to the GV3 Technical Guide for more information.

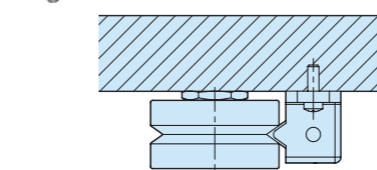

Part Number	Options Available				
	- Metal Shields	NS Nitrile Seals	- Twin Bearings	DR Double Row Bearings	CH Controlled Height Bearings
... J 13 ...	x	✓	✓	x	✓
... J 18 ...	x	✓	✓	✓	✓
... J 25 ...	✓	✓	✓	✓	✓
... J 34 ...	✓	✓	✓	✓	✓
... J 54 ...	✓	✓	✓	✓	✓

Ordering Details

Fixing type. Choose from: **LJ 25 C (DR) (NS) (CHK)**

SJ = Short Axle, **LJ** = Long Axle & **BHJ** = Blind Hole Fixing

Part Number (~ Bearing Diameter in mm)

C = Concentric (fixed), **E** = Eccentric (adjustable) or **DE** = Double Eccentric (for disengagement purposes)

Controlled Height*4 Leave blank if not required

Nitrile Sealed Bearing Leave blank if metal shields are required

Double Row Bearing Leave blank if Twin Bearing is required

HepcoMotion Slimline Bearings are very compact due to the single ball track design. Good rigidity is maintained by a combination of ball to raceway conformity and low radial clearance, resulting in a low cost Bearing ideally suited to many Slide System applications. Performance of these Bearings has been confirmed by rigorous testing.

Slimline Bearings are designed to be used with particular sizes of Slide but may be "Mix & Matched" in many instances*5.

The following Bearing formats and fixing methods are available:

The Nitrile Sealed option (NS) provides a higher degree of protection against ingress of water or debris in comparison to the default metal shielded type. A small increase in friction may result.

The Through Hole Fixing type is available in two axle lengths, with the short axle version being compatible with GV3 Slimline Carriage Plates. Both versions are available in the fixed position **Concentric type (C)** and adjustable **Eccentric type (E)**.

Through Fixing Type (GSJ/GLJ)

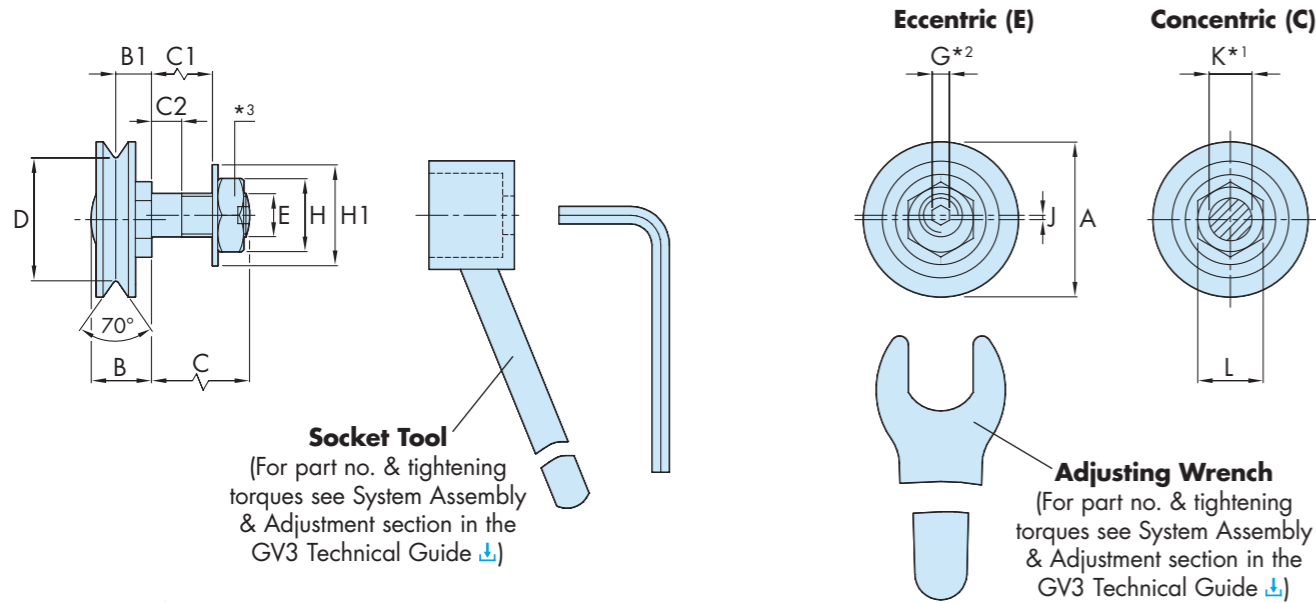

Short Axle / Long Axle
(GSJ) / (GLJ)

Part Number	Use With*5	A	B	B1	C		C1 max		C2		D ±0.025	E Metric Fine	F	G*2	H	H1	J	K*1 +0 -0.03	L	M	N	P	P1	Q	Q1	Q2	R ±0.1	R1	S	T	U	V
					Short Axle	Long Axle	Short Axle	Long Axle	Short Axle	Long Axle																						
... J 195 ...	NV & V	19.5	9.2	5.7	7.4	14	3.4	10	2.4	2.5	14.8	M6x0.75	5	2.5	10	13	0.7	6	11	7.4	1.2	8	10.5	8.6	4	8	38	54	11	24.5	M4	7
... J 265 ...	NS & S	26.5	11.3	6.8	9.8	19	3.8	13	3.4	4.9	19.98	M8x1	7	3	13	17	0.75	8	13	9.8	1.5	7	9	11	5	10	50	72	14	32	M5	8.5
... J 360 ...	NM & M	36	14	8.3	13.8	22	6.6	14.8	5.2	5.9	27.57	M10x1.25	9	4	17	21	1	10	15	13.8	2	9.5	11.3	13.3	6.5	12.5	60	90.5	17	42	M6	10
... J 580 ...	NL & L	58	22.8	14.3	17.8	30	8.2	20.4	5.7	7.9	46.08	M14x1.5	14	6	22	28	1.5	14	27	17.8	3	14.5	16.4	21.9	10.5	18.5	89.5	133	25	62	M8	13

Part Number	Max Working Load Capacity (N)		Bearing Static (Co) and Dynamic (C) Load Capacity (N)*4			
	Radial	Axial	Radial Loads		Axial Loads	
			Co	C	Co	C
... J 195 ...	240	100	563	1366	164	398
... J 265 ...	575	235	1267	3075	310	751
... J 360 ...	1200	500	2470	5625	530	1206
... J 580 ...	2600	1060	6324	12915	1079	2204

Part Number	Options Available	
	-	NS
... J 195 ...	Metal Shields	Nitrile Seals
... J 265 ...	✓	✓
... J 360 ...	✓	✓
... J 580 ...	✓	✓

Notes:

- It is recommended that holes to suit Bearing mounting axles should be reamed to tolerance F6 for a sliding fit.
- All eccentric Through Fixing type Bearing axles are supplied with sockets for adjustment as shown.
- Nuts for the Through Fixing type Bearings are chemically blacked on the concentric version and bright zinc plated on the eccentrics for identification purposes.
- The quoted static and dynamic load capacities are based on industry standard calculations. These do not accurately reflect system performance, and are only provided for comparison with other systems. Please use the Max Working Load figures and the Load/life Calculations section to determine system performance.
- The preferred choices of Slide to use with each Bearing are quoted. Other Slides may be used, as shown in the 'Mix & Match' Component Compatibility section of the GV3 Technical Guide [↓](#).
- The Blind Hole Eccentric Bearings cannot be fitted with Cap Wipers, however, Lubricators may be specified instead.

The Blind Hole Fixing type (BH) allows mounting into a solid machine base where through mounting is not possible, or where adjustment from the front is preferred. They are available in **Concentric type (C)**, which are fixed, and **Eccentric type (E)**, which are adjustable.

All Bearings are greased for life internally. Customers are strongly recommended to provide lubrication to the interface between Bearings and Slide by specifying Hepco Cap Wipers*6, which fit over the Bearings, or by using Hepco Slimline Slide Lubricators. Lubrication greatly increases load capacity and life.

See Application Examples on [10 - 12 & 15](#)

Blind Hole Fixing Type (GBHJ)

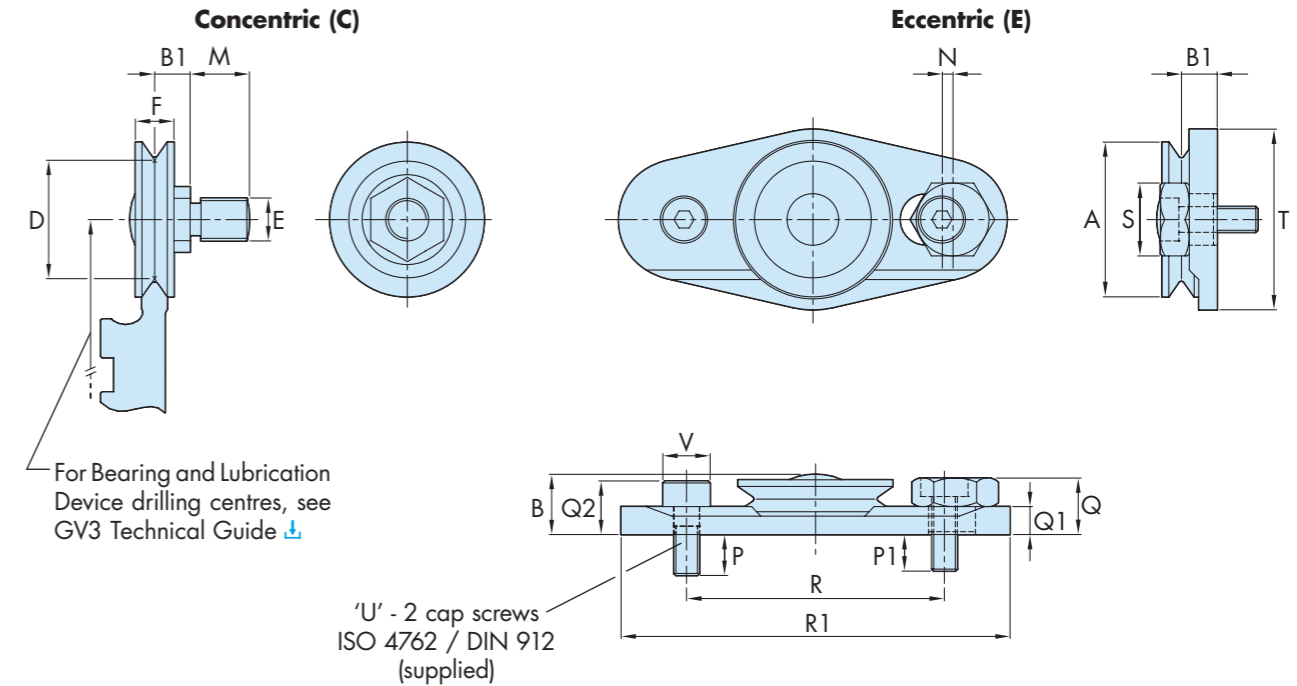

Ordering Details

Fixing type. Choose from: **GLJ** = Short Axle, **GLJ** = Long Axle & **GBHJ** = Blind Hole Fixing

Part Number (~10x Bearing Diameter in mm) **GLJ 265 C (NS)**

C = Concentric (fixed), **E** = Eccentric (adjustable)

Leave blank if metal shields are required

NS = Nitrile Sealed Bearings

Cap Seals

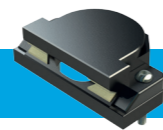

HepcoMotion.com

HepcoMotion flexible plastic Cap Seals fit over **Standard Bearings**, providing effective sealing and protection, as well as wiping of debris from the **Slide** profile. Lubrication of the 'V' surface is provided by means of oil impregnated felt wipers. The internal cavity is filled with grease via the lubrication points, further improving lubrication and recharging the felt wipers as the grease releases oil under operation. Most systems require no further lubrication during the lifetime of the machine*³. The fitting of these seals increases life and load capacity, and linear speed capability, as well as improving operator safety. Cap Seals are not available for use with Blind Hole Eccentric type **Bearings** and J13 Bearings.

See Application Examples on 11 - 14 & 16



Both types of insert supplied.

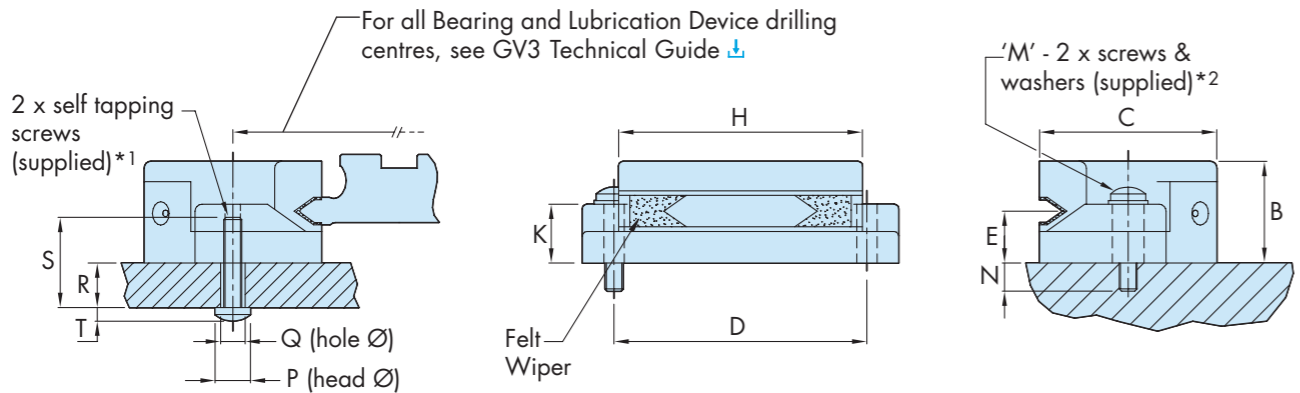
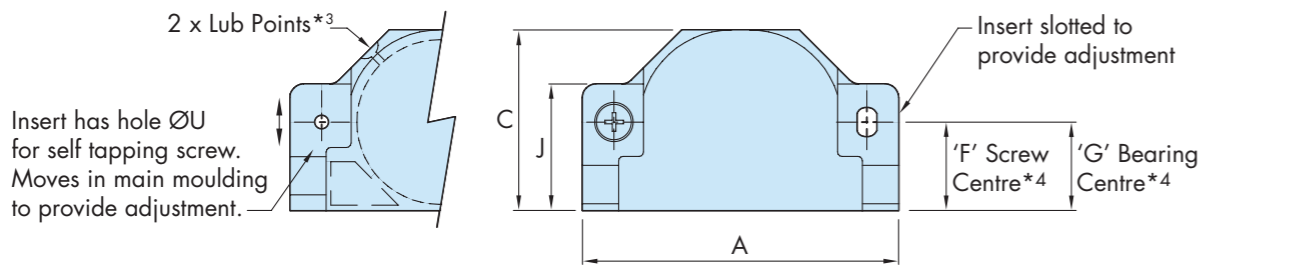

Part Number	Use With	A	B	C	D	E	F	G	H	J	K	M* ²		N	P	Q	R	S	T	U	
												Screw	Length								
CS 18 * ⁴	... J 18 ...	42	13.8	21.2	±0.1	6.75	12.3	10.4	32.3	18	6	M2.5	12	5.5	4.5	3	8.5	12	2	2	2
CS 25	... J 25 ...	55	18	30	±0.1	9	14.8	14.8	43	22	8.6	M3	12	2.9	5.5	3.5	11	16	2	2.5	2.5
CS 34	... J 34 ...	70	22.5	40	±0.1	11.5	19.6	19.6	54	28	13	M4	20	6.2	7	4.5	14	20	2.7	3.3	3.3
CS 54	... J 54 ...	98	36.5	60	±0.1	19	29.7	29.7	78	40	20	M5	25	4	9	6	24	35	3.5	4	4

Part Number	Suitable for Slide Sections				
	MS	V	S	M	L
CS 18 * ⁴	x	✓	✓	✓	✓
CS 25	x	x	✓	✓	✓
CS 34	x	x	x	✓	✓
CS 54	x	x	x	x	✓

Ordering Details

State quantity and part number 4 x CS 34

Notes:

- Two self tapping screws for plastic are supplied with each Cap Seal. These have a cross-recessed pan head and use the PT thread form.
- Two machine screws with cross-recessed pan heads (DIN7985A/ISO7045) and two flat washers (DIN125A) are supplied.
- Lubrication interval depends on length of stroke, duty and environmental factors. Replenish lubricant as necessary using a No.2 consistency lithium soap based grease. A mole grease connector Part No. CSCHF4034 or a complete gun is available from Hepco if required.
- The fixing screw positions for the CS18 do not lie on the centreline of the nominal **Bearing** position, unlike all other sizes.

Cap Wipers

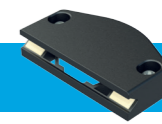

HepcoMotion.com

HepcoMotion rigid plastic Cap Wipers fit over **Slimline Bearings**, providing effective protection, plus wiping of debris from the **Slide** profile. Lubrication of the 'V' surface is provided by means of oil impregnated felt wipers. The internal cavity is filled with grease via the lubrication points, further improving lubrication and recharging the felt wipers as the grease releases oil under operation. Most systems require no further lubrication during the lifetime of the machine*³. Fitting of Cap Wipers increases life and load capacity, and linear speed capability, as well as improving operator safety. Cap Wipers are not available for use with Blind Hole Eccentric type **Bearings**.

See Application Example on 12

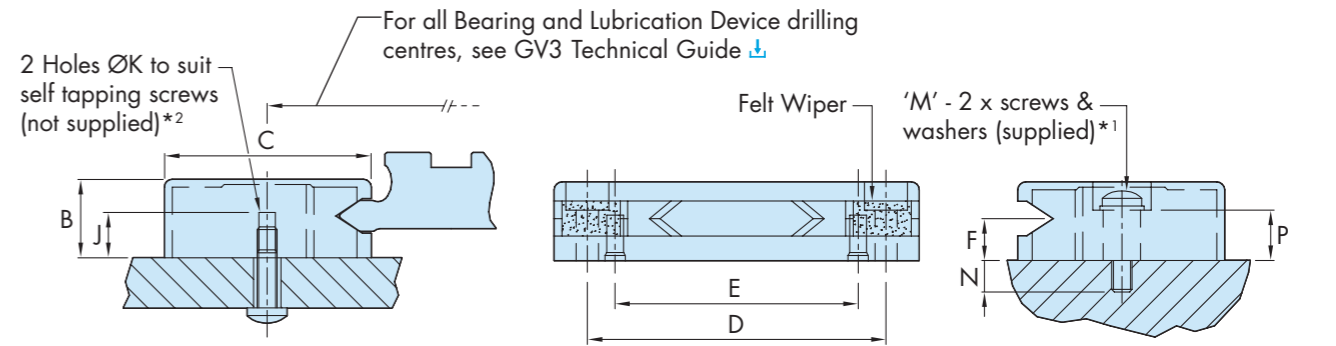
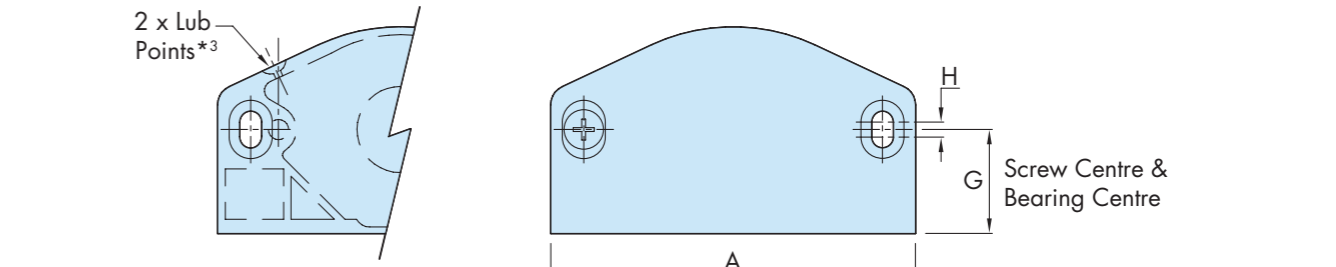

Part Number	Use With	A	B	C	D	E	F	G	H	J	K	M* ¹		N	P
												Screw	Length		
CW 195	... J 195 ...	43	11.2	22.8	±0.1	±0.1	5.7	11.3	2	7	2.4	M2.5	12	3	8.5
CW 265	... J 265 ...	54	13	30.3	±0.1	±0.1	6.8	15.3	2.5	8.5	2.8	M3	16	5.5	10
CW 360	... J 360 ...	72	15.5	40.8	±0.1	±0.1	8.3	20.5	3	9	3.8	M4	16	5.5	10
CW 580	... J 580 ...	106	25	63.3	±0.1	±0.1	14.3	31.8	3.5	18	4.8	M5	25	4	20

Part Number	Suitable for Slide Sections				
	MS	V	S	M	L
CW 195	x	✓	x	x	x
CW 265	x	x	✓	x	x
CW 360	x	x	x	✓	x
CW 580	x	x	x	x	✓

Ordering Details

State quantity and part number 4 x CW 360

Notes:

- Two cross-recessed pan head screws to DIN7985A/ISO7045 and washers (DIN433) are supplied with each Cap Wiper.
- Cap Wipers may be secured using the blind holes 'K' in the underside. These may be tapped thread form 'M' to take a machine screw, or will accept a self tapping screw. The mounting holes will require slotting to provide adjustment.
- Lubrication interval depends on length of stroke, duty and environmental factors. Replenish lubricant as necessary using a No.2 consistency lithium soap based grease. A mole grease connector Part No. CSCHF4034 or complete gun is available from Hepco, if required.

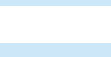
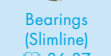
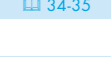
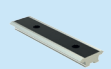

HepcoMotion plastic Slide Lubricators normally fit one each side of the Slide, between pairs of Bearings. However, any number may be fitted in any position according to requirements. Lubricators provide lubrication to the working surface of the Slide by means of spring loaded oil impregnated felt wipers.

System load capacity and life are greatly increased whilst retaining the low friction characteristics of dry running. Lubricators may be specified as part of any Hepco GV3 Carriage assembly or used within the customers' own design.

Lubricators are available to suit both Standard and Slimline Bearings. Both types are supplied with fasteners and can be attached with either a blind or through hole fixing.

See Application Examples on 10, 13, 15 & 16

Slide Lubricators for Standard Bearings

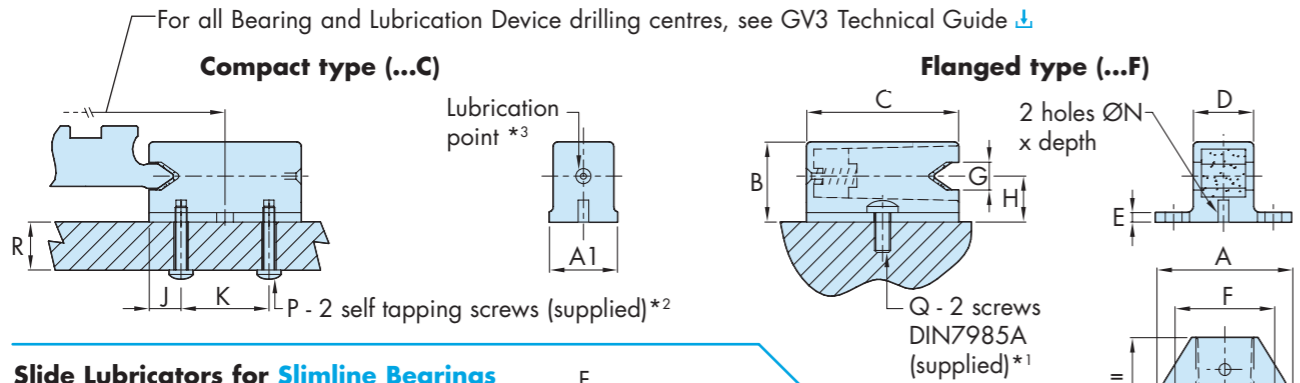

Slide Lubricators for Slimline Bearings

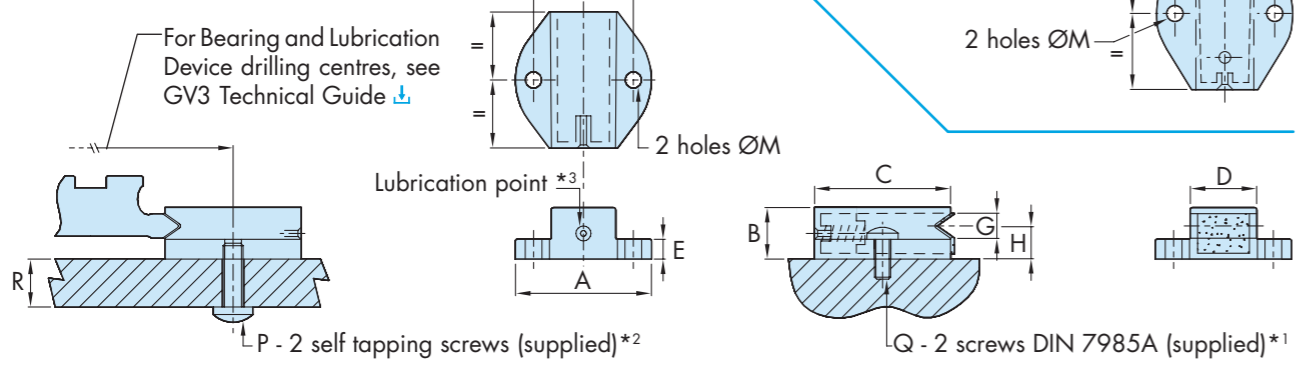

Part Number	A	A1	B	C	D	E	F ±0.1	G	H	J	K ±0.1	M	N	P*2		Q*1		R max	min
														Thread x Length	Thread x Length	Thread x Length	Thread x Length		
LB 12 *4	17	7	10	13	5.2	2	12	3.1	5.46	3	6.5	2.7	1.7x2.5	Ø2.5x5	M2.5x6	3	2.5		
LB 20 *4	19	8	12	22.5	6.5	2	13	7.2	6.75	4.75	13	2.7	1.7x2.5	Ø2.5x10	M2.5x6	8	7.5		
LB 25	25	12	16.5	28	9.9	2	18	5.5	9	6	16	3.2	2.4x4.5	Ø3x10	M3x8	7.5	5.5		
LB 44	34	17	20	38	15	2.4	25	7	11.5	8	22	4.2	2.4x5.5	Ø3x16	M4x10	13.5	11.5		
LB 76	50	25	33.5	57	22.7	4.5	38	10	19	12	33	5.2	2.7x9	Ø3.5x22	M5x12	18.5	13		
LB 195	19	-	8.7	19.8	6.85	5	13	4.1	5.7	-	-	2.7	-	Ø3x12	M2.5x10	9	-		
LB 265	25	-	10.3	25	11.5	4	18	4.7	6.8	-	-	3.2	-	Ø3.5x12	M3x8	8.5	-		
LB 360	34	-	12.9	34	16.6	5	25	6.2	8.3	-	-	4.2	-	Ø5x16	M4x10	11	-		
LB 580	50	-	21.9	57	26.5	7.5	38	12.5	14.3	-	-	5.2	-	Ø6x25	M5x16	19	-		

Part Number	Use With	Suitable for Slide Sections							Types Available	
		MS	V	S	M	L	Flanged (F)	Compact (C)		
		✓ = Preferred choice, ✓ = Compatible, ✗ = Not Compatible								
LB 12 *4	...J 13...	✓	✓	✓	✓	✓	✓	✓	✓	
LB 20 *4	...J 18...	✗	✓	✓	✓	✓	✓	✓	✓	
LB 25	...J 25...	✗	✓	✓	✗	✗	✓	✓	✓	
LB 44	...J 34...	✗	✗	✗	✓	✗	✓	✓	✓	
LB 76	...J 54...	✗	✗	✗	✗	✓	✓	✓	✓	
LB 195	...J 195...	✓	✓	✓	✓	✓	✓	✓	✗	
LB 265	...J 265...	✗	✓	✓	✓	✓	✓	✓	✗	
LB 360	...J 360...	✗	✗	✓	✓	✓	✓	✓	✗	
LB 580	...J 580...	✗	✗	✗	✓	✓	✓	✓	✗	

Ordering Details

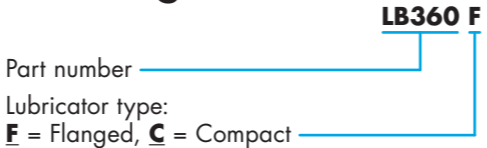

- Notes:
- Two machine screws with cross-recessed pan heads size Q (DIN 7985A / ISO 7045) are supplied with each flanged type and slimline Lubricator.
 - Two self tapping screws for plastic (size P) are supplied with each compact type Lubricator. These have a cross-recessed pan head and PT thread form.
 - Lubrication interval depends on length of stroke, duty and environmental factors. Replenish lubricant as necessary using a 68 viscosity EP mineral oil.
 - Sizes LB12 and LB20 have a true 'V' shape to enable them to engage with Slide thicknesses larger than their G dimensions.



The HepcoMotion Bleed Lubrication facility enables a constant flow of lubricant to be channelled directly to the 'V' surfaces of the Slide. The lubricant is distributed along the length of the Slide by the Bearings as they run up and down. Most efficient distribution is achieved by also fitting Hepco Cap Seals / Wipers or Lubricators, which will be continuously charged with fresh lubricant and ensure an even spread over the working surfaces.

Bleed Lubrication is the best method of lubrication for continuous duty systems requiring long life.

The Bleed Lubrication facility is available with either an M5 screw fitting insert or an O-ring seal insert. Connection can be made to a centralised lubrication system, pressure feed canister or an oil dispensing pump and controller, which can be programmed to meter a set dose of lubricant, according to the distance travelled by the Carriage.

For full information, please see the GV3 Technical Guide.

See Application Example on 8

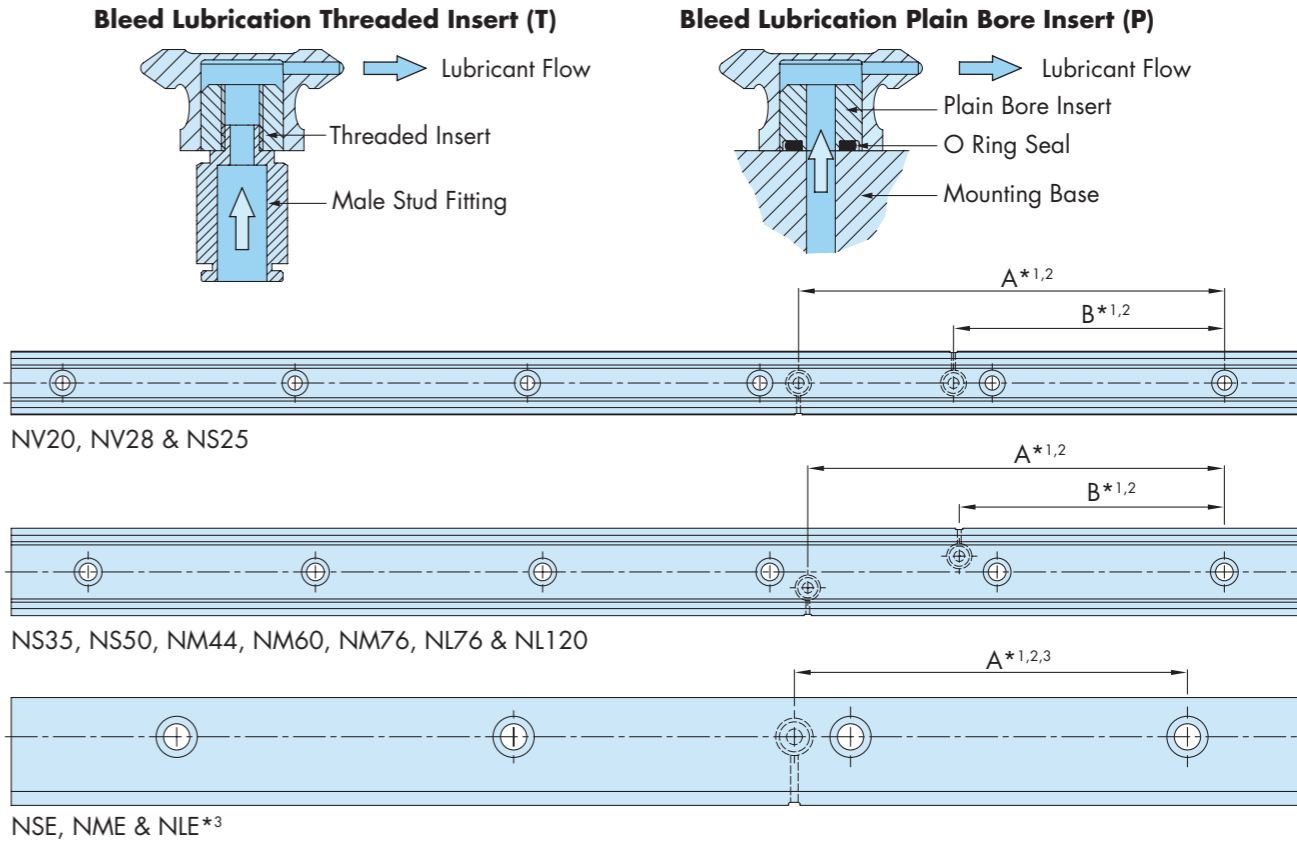

Slide Part Number	For Use With	A*1,2	B*1,2
NMS12		Bleed lubrication unavailable	
NV20, NV28, NS25, NS35, NS50, NM44, NM60 & NM76		435	375
NL76, NL120		330	210
NMSE & NVE		Bleed lubrication unavailable	
NSE & NME		375*3	-
NLE		390*3	-

Ordering Details

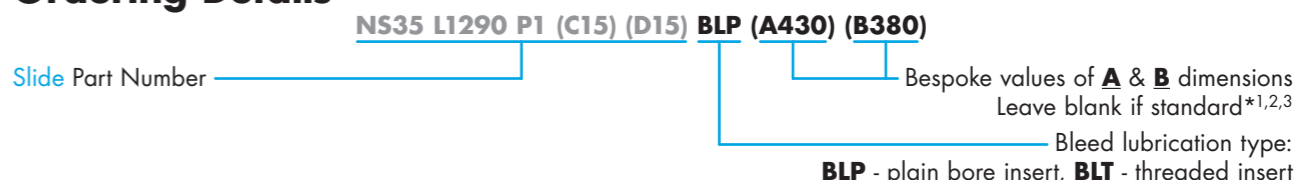

Ordering Example:
 1 x NME L2336 P2 BLP A400 — Single Edge Spacer Slide, 2336mm long, P2 grade, with custom hole position A
 1 x NME L2336 P2 BLP A1850 — Single Edge Spacer Slide, 2336mm long, P2 grade, with custom hole position A

- Notes:
- Dimensions A and B are distances from the centre of the mounting hole positioned nearest to the right-hand end of the Slide.
 - Custom position bleed holes can be specified, but cannot be located more than 600mm from the end of the Slide. Mounting holes should be avoided.
 - To order a symmetrical pair of Single Edge Spacer Slides with Bleed Lubrication, one of the Slides should be an opposite handed version, with an adjusted bleed hole position dimension A to reflect this. This is shown in the ordering example above.

HepcoMotion GV3 Flat Tracks are made from high quality carbon steel and are hardened on all four faces to provide an extremely durable running surface. They have been designed to be used with the Hepco range of [Track Rollers](#). Flat Tracks are often used in conjunction with Hepco 'V' [Slides](#) in large systems where the design can eliminate the requirement to set Slides accurately parallel. They are available with various precision ground faces (as shown below), as well as unground P3 grade, which has a commercial finish suitable for many applications*4.

It is recommended that running surfaces should be kept lightly oiled. HepcoMotion GV3 Flat Track and Roller Lubricators are available for this purpose. Please see the GV3 Technical Guide [↓](#) for more information.

See Application Examples on [5](#)

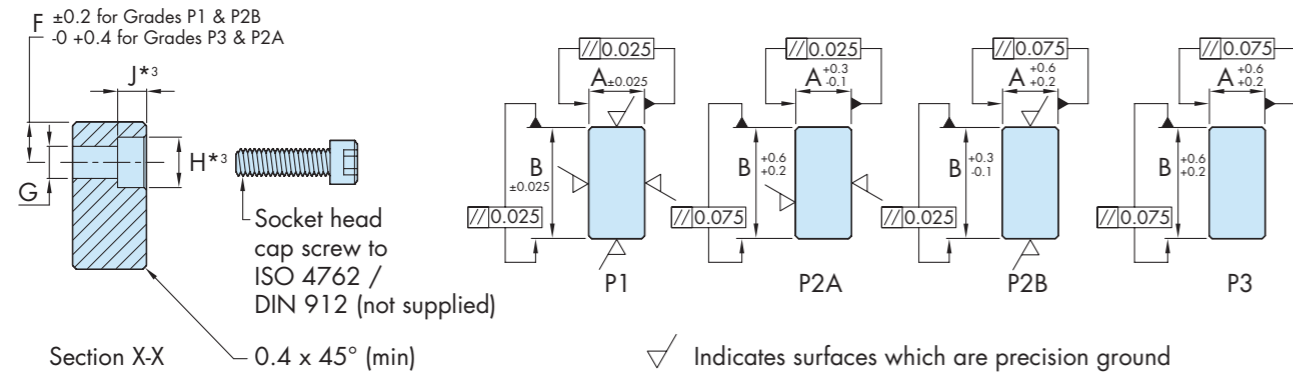
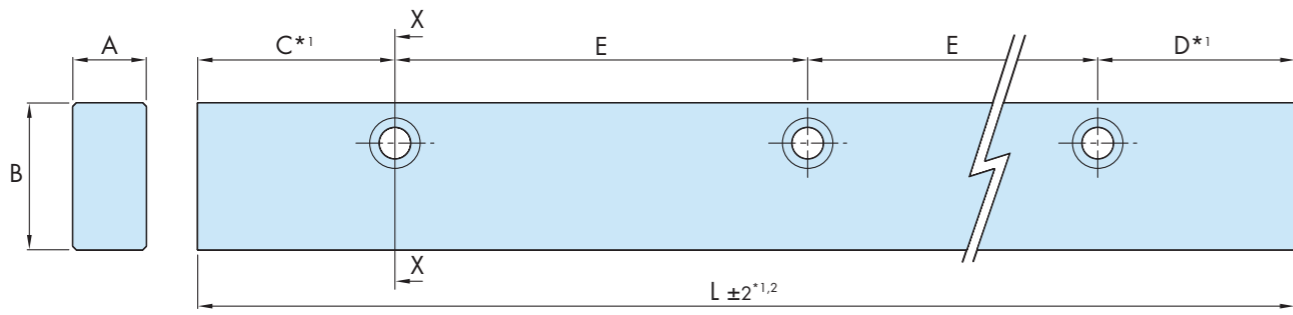

Part Number	Use With		A		B		C*1	D*1	E	F	G	Screw Size	H*3	J*3	L*1,2 max
	...R 18...	LRN 18...	P1 & P2A	P2B & P3	P1 & P2B	P2A & P3									
FT 24 12	...R 18...	LRN 18...	12	12.4	24	24.4	20.5	20.5	45	7.5	6	M5	10	5	2000
FT 32 16	...R 25...	LRN 25...	16	16.4	32	32.4	43	43	90	8.75	7	M6	11	6	4020
FT 40 20	...R 34...	LRN 34...	20	20.4	40	40.4	43	43	90	12	9	M8	15	8	4020
FT 66 33	...R 54...	LRN 54...	33	33.4	66	66.4	88	88	180	17	14	M12	20	12	4020

Ordering Details

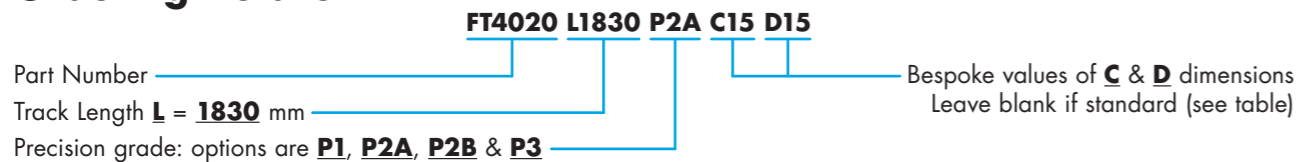

- Notes:**
- Any length of Flat Track within max length stated can be supplied, but for optimum price and delivery time, track lengths should be specified which maintain the C and D dimensions in the table above. In all cases, unless otherwise specified by the customer, C and D dimensions will be supplied equal.
 - Where Tracks longer than maximum length are required, two or more lengths in grades P1, P2A & P2B can be matched, suitable for butting, on request. In these cases the mating ends will be ground square.
 - The standard means of securing Flat Tracks to the mounting surface is via counterbored fixing holes in the positions shown. Other fixing hole possibilities are available on request. It is recommended that holes in the mounting surface are positioned by 'spotting through' from the Flat Track.
 - Important.** Tracks in their free unmounted state are not necessarily absolutely straight, however, they may be set to the required degree of straightness during installation.

HepcoMotion Narrow Track Rollers complement the other GV3 ranges of [Bearings](#). They are available in through hole fixing format, in a single axle length, in both fixed position **Concentric Type (C)** and adjustable **Eccentric Type (E)**.

Narrow Track Rollers consist of a high capacity single row deep groove ball bearing with a thick wall crowned outer ring. They are fitted with metal shields as standard, or with nitrile seals for better protection against liquids at the expense of a small increase in friction. They are suitable for running on any flat surface and as a retaining roller on the rear face of the [Single Edge Spacer Slide](#).

Rollers are greased for life internally, however, it is recommended to oil the running surface. HepcoMotion GV3 Flat Track Lubricators are available for this purpose. Please see the GV3 Technical Guide [↓](#) for more information.

See Application Example on [5](#)

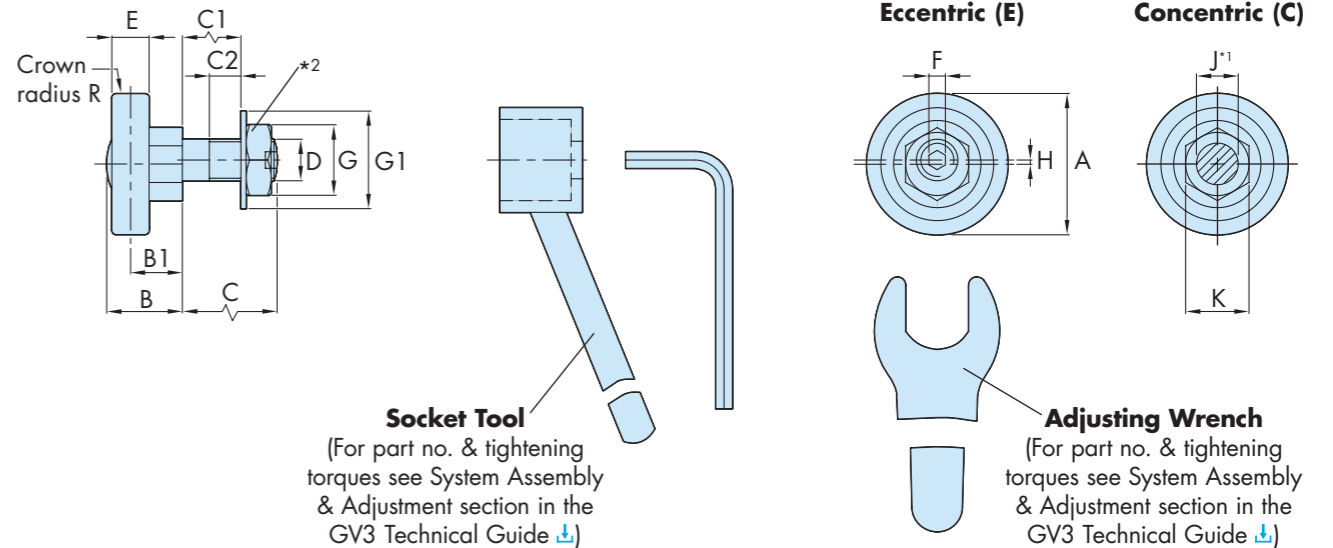

Part Number	Use With*4	A	B	B1	C	C1	C2	D	E	F	G	G1	H	J*1	K	R
		Metric Fine														
LRN 18 ...	FT 24 12	18	11.5	8	14	10	2.5	M6x0.75	5	2.5	10	13	0.7	6	11	500
LRN 25 ...	FT 32 16	25	14.5	10	19	13	5	M8x1	7	3	13	17	0.75	8	13	500
LRN 34 ...	FT 40 20	34	18.2	12.5	22	14.8	6	M10x1.25	9	4	17	21	1	10	15	500
LRN 54 ...	FT 66 33	54	29.5	21	30	20.4	8	M14x1.5	14	6	22	28	1.5	14	27	500

Part Number	Max Working Load Capacity (N)	Roller Static (Co) and Dynamic (C) Load Capacity*3		Part Number	Options Available	
		Co (N)	C (N)		-	NS
LRN 18 ...	400	593	1438	LRN 18 ...	×	✓
LRN 25 ...	1000	1333	3227	LRN 25 ...	✓	✓
LRN 34 ...	2000	2600	5921	LRN 34 ...	✓	✓
LRN 54 ...	5000	6657	13595	LRN 54 ...	✓	✓

Ordering Details

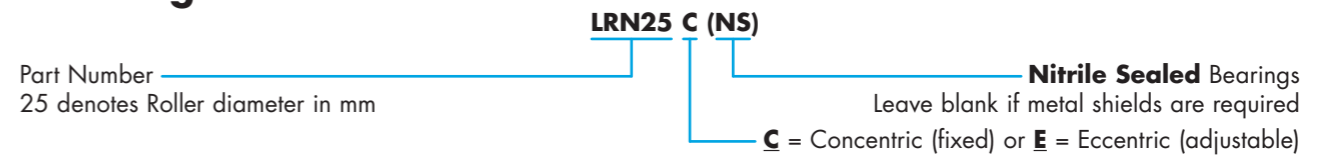

- Notes:**
- It is recommended that holes to suit Track Roller mounting axles should be reamed to tolerance F6 for a sliding fit.
 - Nuts are chemically blacked on the concentric version and bright zinc plated on the eccentric version for identification purposes.
 - The quoted static and dynamic load capacities are based on industry standard calculations. These do not accurately reflect system performance, and are only provided for comparison with other systems. Please use the Max Working Load figures and the Load/Life Calculations on [50-52](#) to determine system performance.
 - Each size of Narrow Track Roller has been designated for use with a specific size of [Flat Track](#), as shown. However, any Track Roller may be used in conjunction with any size of Flat Track, [Single Edge Slide](#) or other running surface according to practicality of design.

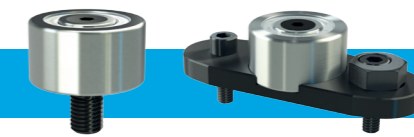

HepcoMotion Wide Track Rollers can be used with Hepco Flat Tracks, the back face of Single Edge Spacer Slides and on any other type of running surface. Rollers comprise of a high capacity double row deep groove ball bearing, with a substantial section outer ring and crowned profile.

The **Through Hole Fixing type** is available in two axle lengths covering most thicknesses of mounting plate.

The **Blind Hole Fixing type** can be used where through holes are not possible, or where adjustment from the front is preferred.

Both versions are available in fixed position **Concentric type (C)** and adjustable **Eccentric type (E)**.

Through Fixing Type (SR/LR)

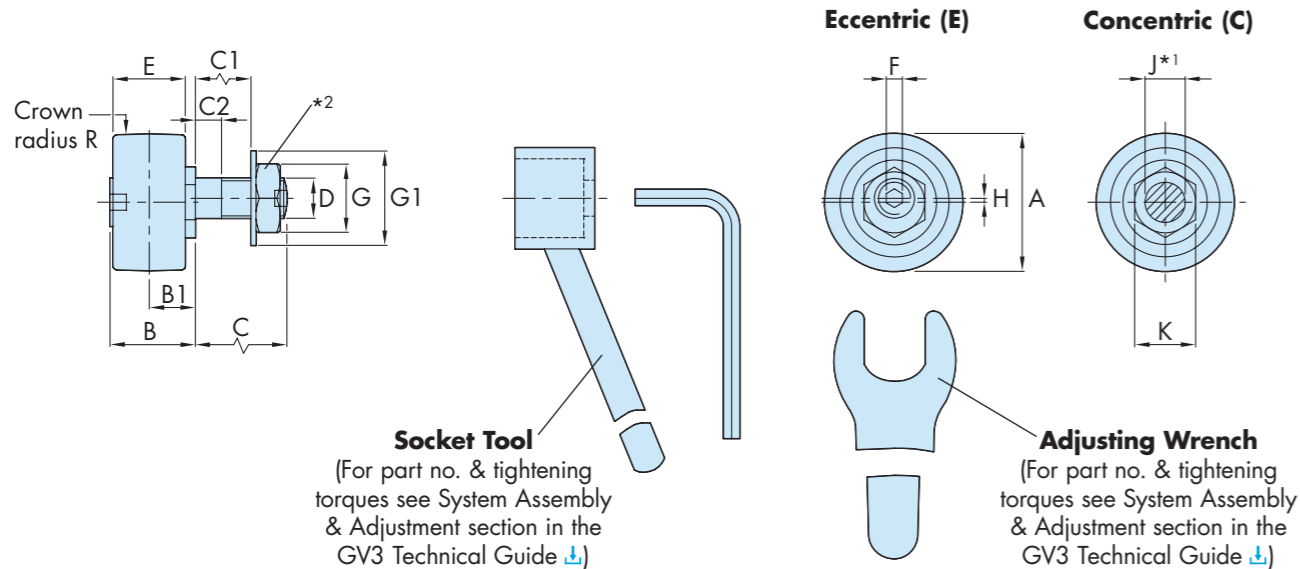

Short Axle / Long Axle
(SR) / (LR)

Part Number	Use With*4	A	B	B1	C		C1 max		C2		D Metric Fine	E	F	G	G1	H	J*1 +0.00 -0.03	K	L	M	N	N1	P	P1	P2	Q	Q1	R	S	S1	T	U	V
					Short Axle	Long Axle	Short Axle	Long Axle	Short Axle	Long Axle																							
... R 18 ...	FT 24 12 ...	18	12.4	6.75	7.4	14	3.4	10	2.4	2.5	M6 x 0.75	10	2.5	10	13	0.7	6	11	7.4	1.2	8	10.5	10	4	8	38	54	500	12.3	7.8	M4	7	11
... R 25 ...	FT 32 16 ...	25	16.6	9	9.8	19	3.8	13	3.4	4.9	M8 x 1	14	3	13	17	0.75	8	13	9.8	1.5	7	9	12	5	10	50	72	1000	16	11	M5	8.5	14
... R 34 ...	FT 40 20 ...	34	21.3	11.5	13.8	22	6.6	14.8	5.2	5.9	M10 x 1.25	18	4	17	21	1	10	15	13.8	2.0	9.5	8.5	17.5	6.5	12.5	60	90.5	1000	21	15.3	M6	10	17
... R 54 ...	FT 66 33 ...	54	34.7	19	17.8	30	8.2	20.4	5.7	7.9	M14 x 1.5	28	6	22	28	1.5	14	27	17.8	3.0	14.5	16.4	23.5	10.5	18.5	89.5	133	1500	31	25	M8	13	25

Part Number	Max Working Load Capacity (N)	Roller Static (Co) and Dynamic (C) Load Capacity*3	
		Co (N)	C (N)
... R 18 ...	600	1168	2301
... R 25 ...	1600	2646	5214
... R 34 ...	3200	5162	9560
... R 54 ...	8000	13271	21989

Rollers are available with either standard metal shields, or nitrile seals (NS), for a higher degree of protection against ingress of water or debris. A slight increase in friction may result.

Wide Track Rollers are available in the same basic sizes as Hepco 'V' Bearings and are well matched for functionality and performance in systems comprising both types of Bearing.

Rollers are greased for life internally, however, it is recommended to oil the running surface. HepcoMotion GV3 Flat Track and Roller Lubricators are available for this purpose. Please see the GV3 Technical Guide [↓](#) for more information.

See Application Example on [5](#)

Blind Hole Fixing Type (BHR)

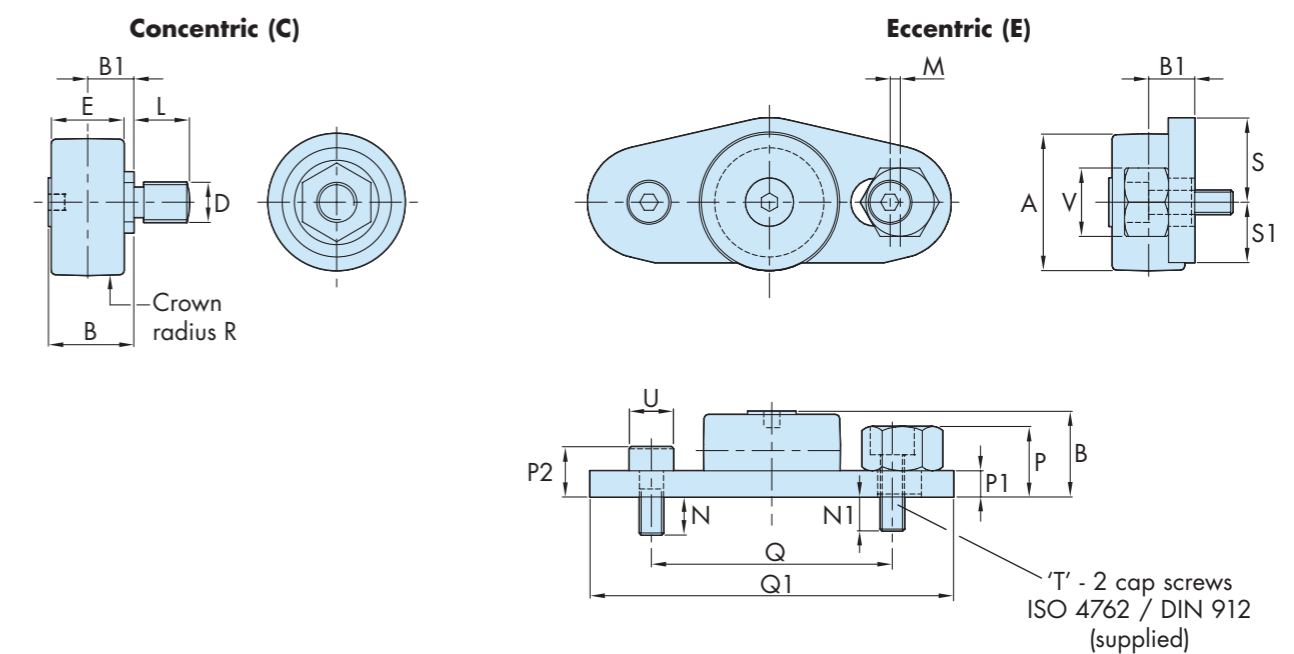

A range of **Flat Track and Roller Lubricators** are available. Please refer to the GV3 Technical Guide [↓](#) for more information.

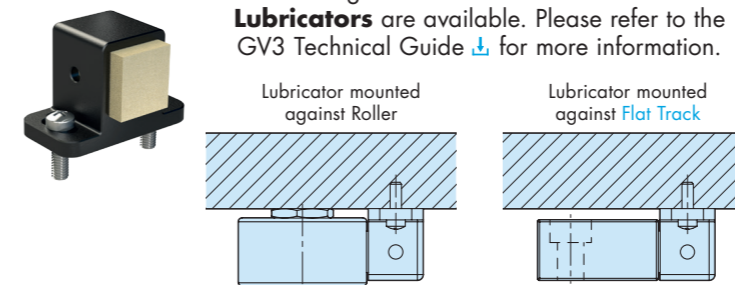

Part Number	Options Available	
	- Metal Shields	NS Nitrile Seals
... R 18 ...	✗	✓
... R 25 ...	✓	✓
... R 34 ...	✓	✓
... R 54 ...	✓	✓

Notes:

- It is recommended that holes to suit Track Roller mounting axles should be reamed to tolerance F6 for a sliding fit.
- Nuts are chemically blacked on the concentric version and bright zinc plated on the eccentrics for identification purposes.
- The quoted static and dynamic load capacities are based on industry standard calculations. These do not accurately reflect system performance, and are only provided for comparison with other systems. Please use the Max Working Load figures and the Load/Life Calculations on [50-52](#) to determine system performance.
- The preferred choice of Flat Track for each size of Roller is listed. However, any Track Roller may be used with any size of Flat Track or Single Edge Spacer Slide according to practicality of design.

Ordering Details

Fixing type. Choose from: **SR** = Short Axle, **LR** = Long Axle & **BHR** = Blind Hole Fixing

Part Number (Roller Diameter in mm) **LR 25 C (NS)**

C = Concentric (fixed) or **E** = Eccentric (adjustable)

NS = Nitrile Sealed Roller
Leave blank if metal shields are required



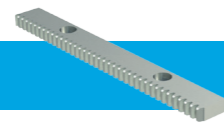

HepcoMotion GV3 Racks provide a durable and powerful linear drive when used in conjunction with Hepco or other good quality, hardened Pinions.

Racks are made from high quality carbon steel, ground on all faces prior to tooth cutting. Teeth are metric module with 20° pressure angle and are machined to a high degree of precision.

Racks are supplied with fixing hole types as shown or without holes if preferred. All holes are accurately positioned to enable customers to pre-drill their mounting holes.

The back face of the Rack is controlled parallel to the tooth pitch line, enabling it to be used as a register for setting*4.

For best performance, the teeth should be lubricated with No.2 consistency lithium soap-based grease.

See Application Examples on 14 - 15

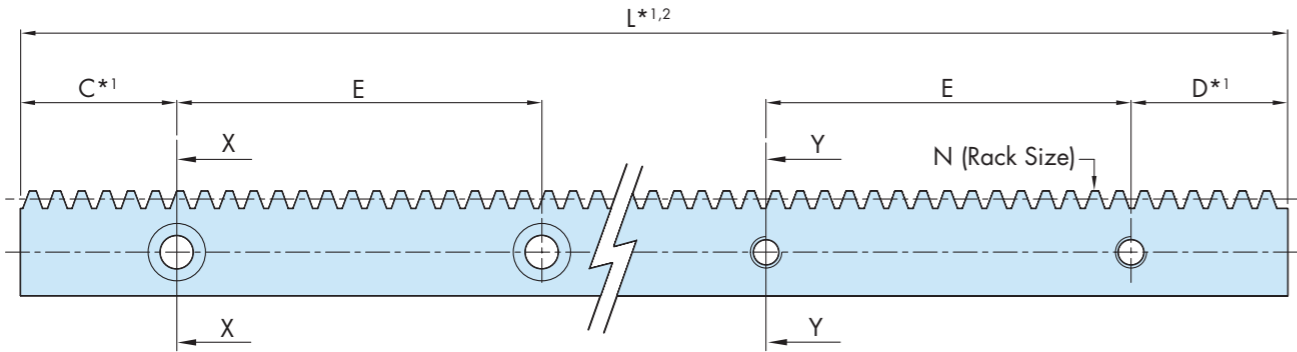

Rack with Counterbored Holes

Rack with Tapped Holes

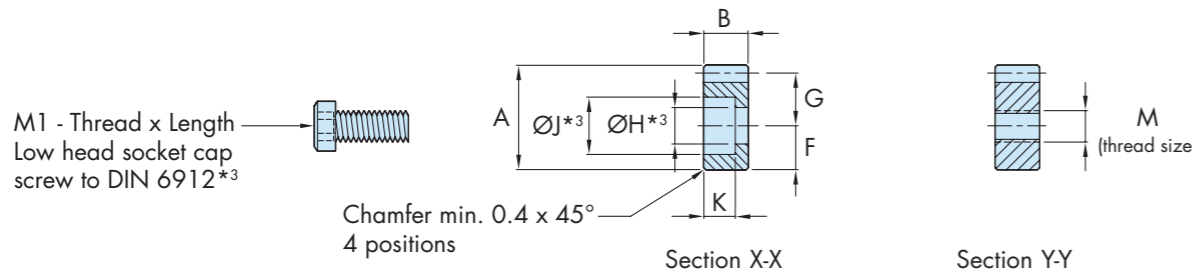

Part Number	Use With	A	B	C*1	D*1	E	F	G	H*3	J*3	K	L*1,2 max	M	M1*3		N mod	Max Rack Force (N)*5
														Screw	Part No.		
R 07 ...	P07 W5...	12.7	4.0	20.5	20.5	45	6.35	5.65	4.5	7.6	2.9	1796	M4	M4 x 10	FS410	0.7	110
R 10 ...	P10 W7...	15.65	6.75	43	43	90	7.8	6.85	5.5	9.6	4.0	1886	M5	M5 x 10	FS510	1.0	250
R 15 ...	P15 W8...	20.0	8.25	43	43	90	8.3	10.2	6.5	11	4.5	2966	M6	M6 x 12	FS612	1.5	400
R 20 ...	P20 W13...	31.75	14.0	43	43	90	13.2	16.55	11	18	10.5	3956	M10	M10	-	2.0	950

Ordering Details

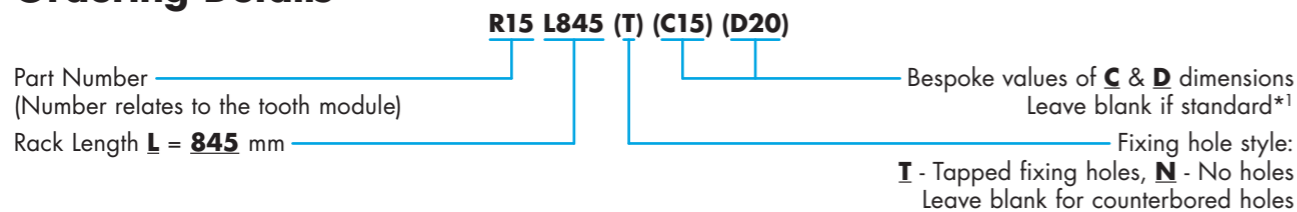

- Notes:**
- Any length of Rack within L max dimension can be supplied, but for optimum price and delivery time, lengths should be specified which maintain the C and D dimensions in the table above. In all cases, unless otherwise specified by the customer, C and D dimensions will be supplied equal.
 - Where longer Racks are required, standard lengths suitably matched for mounting end-to-end, will be supplied. In these cases, additional holes may be inserted to give support near the join positions. When mounting such compound Racks, care must be taken to match accurately the pitch line and tooth spacing across the join. A rack matching tool, which is a short length of Rack to engage in the two pieces to be mounted, will be supplied with such orders.
 - The standard counterbored holes on the three smallest sizes suit low head hex socket cap screws (to DIN 6912). These screws are not universally stocked so Hepco offers them as a convenience to customers in a single length for each thread size (see table). The largest size R20 Racks are thick enough to accommodate cap head screws to ISO 4762 / DIN 912, which are widely available.
 - Racks in their free unmounted state are not necessarily absolutely straight. If straightness is important, the Rack should be set by bolting down to a flat surface with the rear face located against a register. Care should be taken to align parallel with the relevant Slide. Adjustment for the Pinion should be provided in order to achieve the desired mesh quality. For best performance, the teeth should be lubricated with No.2 consistency lithium soap-based grease.
 - The Max Rack Force is the continuous drive force that can be sustained by a well lubricated Rack used in conjunction with the appropriate Hepco Pinion.

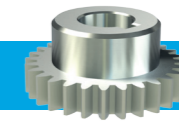

The HepcoMotion range of Pinions is compatible with all Rack cut GV3 components. **Boss Type** Pinions are for general use. **Shaft Type** Pinions, which are detailed in the Technical Guide, are compatible with Hepco Rack Driven Carriages and other designs benefiting from the Hepco Drive Flange and hollow shaft motor driven worm Gearbox. Examples of these designs may be found in the Rack & Pinion Systems section of the GV3 Technical Guide.

All Pinions have hardened teeth and are metric module with 20 pressure angle conforming to ISO 1328-1 grades. Pinions smaller than 1 module conform to ISO 1328-1 grade 10 and are supplied with a plain bore (B type), or with set screw (BK type*). Pinions with modules of 1 and above have hardened and ground teeth, conform to ISO grade 6 and are available in steel as well as stainless steel in some sizes (see table). These Pinions are supplied with a plain bore (B type) or with keyway and set screw (BK type).

See Application Examples on 13 - 15 & 17

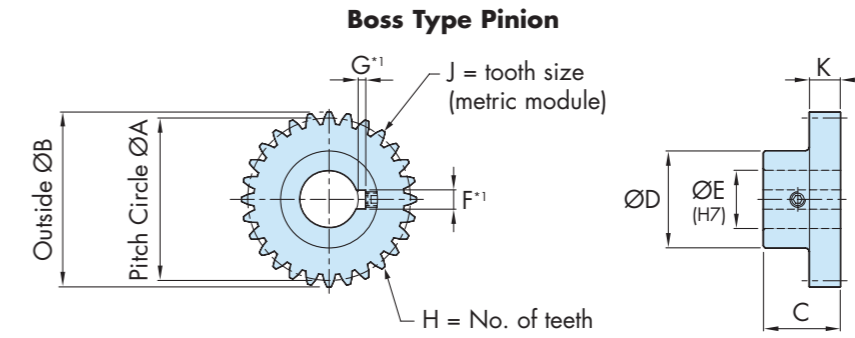

Part Number	Material*2	Condition*3	ISO 1328-1 grade	A	B	C	D	E	F*1	G*1	H	J mod	K
P05 W7 T28 ...	ST	✗	10	14	15	14	10	5	-	-	28	0.5	7
P07 W9 T28 ...	ST	✗	10	19.6	21	17	16	5	-	-	28	0.7	9
P07 W5 T28 ...	ST	✗	10	19.6	21	13	16	5	-	-	28	0.7	5
P10 W11 T42 ...	ST/SS	✓	6	42	44	23	30	15	5	2.3	42	1	11
P10 W7 T42 ...	ST	✓	6	42	44	18.5	30	15	5	2.3	42	1	7
P125 W14 T34 ...	ST/SS	✓	6	42.5	45	25.5	30	15	5	2.3	34	1.25	14
P15 W8 T28 ...	ST	✓	6	42	45	19.8	30	15	5	2.3	28	1.5	8
P20 W20 T27 ...	ST/SS	✓	6	54	58	35	40	20	6	2.8	27	2	20
P20 W13 T27 ...	ST	✓	6	54	58	25	40	20	6	2.8	27	2	13

Part Number	For Use With			
P05 W7 T28 ...	-	NMSE ... R	-	-
P07 W9 T28 ...	-	NVE ... R	-	-
P07 W5 T28 ...	R07 ...	-	NV ... R	-
P10 W11 T42 ...	-	NSE ... R	-	WG3 ...
P10 W7 T42 ...	R10 ...	-	NS ... R	-
P125 W14 T34 ...	-	NME ... R	-	WG4 ...
P15 W8 T28 ...	R15 ...	-	NM ... R	WG3 ...
P20 W20 T27 ...	-	NLE ... R	-	WG4 ...
P20 W13 T27 ...	R20 ...	-	NL ... R	WG4 ...

Ordering Details

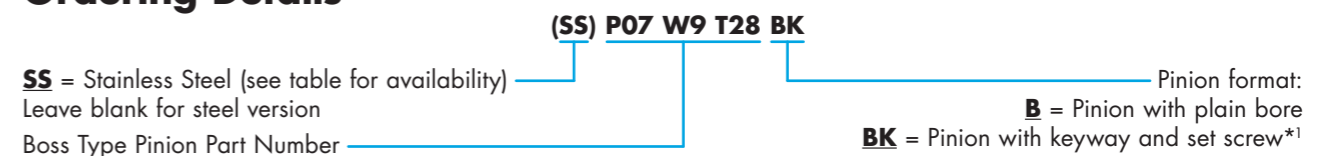

Notes:

- Small "BK" type Pinions with bores below 8mm are supplied with set screw through to the bore but without keyway. It is usual practice to secure these Pinions by means of a set screw onto a flat on the shaft or by using a taper pin.
- ST = steel, SS = stainless steel. Stainless steel Pinions are ground all over for corrosion resistance.
- ✓ = Hardened all over. Teeth and bore ground. ✗ = Teeth hardened only. Teeth not ground.

HepcoMotion Rack Driven Carriages are an economic means of achieving a powerful and controlled linear drive via the Hepco Worm Gearbox, Drive Flange and Shaft Pinion.

The Gearbox can be supplied with an integral AC Motor, which is the most economical means of achieving point to point linear motion and which may be controlled via the Hepco AC Speed Controller. The Gearbox can also be supplied with an adaptor flange and input shaft coupling to suit other makes or types of motor, including steppers and servos, which benefit from the low backlash of the Hepco Gearbox.

Carriage Plates are precision machined from aluminium alloy and are supplied anodised.

Please refer to the Rack & Pinion Systems section of the GV3 Technical Guide for illustrations of other compatible systems using the Hepco Worm Gearbox, Drive Flange and Shaft Pinion.

Our Technical Department will be pleased to assist with all aspects of specification and ordering.

Double Edge Spacer Slide Rack Assembly 26-27

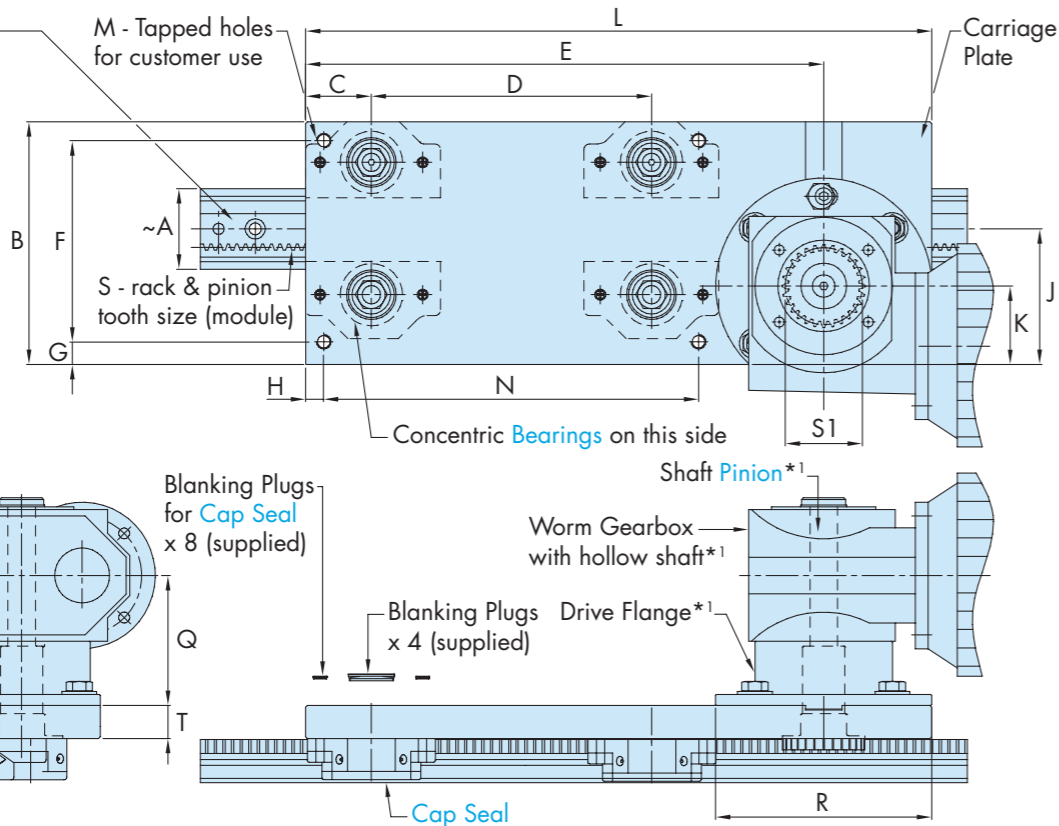

Part Number ¹	A	B	C	D	E	F	G	H	J	K	L	M	N	P		Q	R	S	S1	T	Rack Drive Force (N) ³
														P1	P2 & P3						
AURD 44 34 L300 CS DR	44	133	36	112	240	113	10	10	74.1	43	300	M8	164	42	42.25	71	118	1.5	42	18	400
AURD 44 34 L420 CS DR				232	360								420	284							
AURD 60 34 L320 CS DR	60	144	36	132	260	124	10	10	74.1	43	320	M8	184	42	42.25	71	118	1.5	42	18	400
AURD 60 34 L440 CS DR				252	380								440								
AURD 76 34 L320 CS DR	76	154	36	132	260	134	10	10	74.1	43	320	M8	184	42	42.25	71	118	1.5	42	18	400
AURD 76 54 L360 CS DR	76	193	51	115	285								168								
AURD 76 54 L500 CS DR							255	425						500		327					
AURD 120 54 L380 CS DR	120	240	51	135	305	210	15	15	119.8	111.3	380	M10	207	58.5	58.75	72.5	147	2	54	20	700
AURD 120 54 L540 CS DR				295	465								367								

Ordering Details

Part Number **AURD 60 34 L440 CS DR** + Part Number for AC Geared Motor or Worm Gearbox see GV3 Technical Guide + Part Number for Double Edge Spacer Slide with fitted Rack

CS for Cap Seals*2
DR for Double Row Bearings*2

Notes:

- Gearbox ratios and all details of Shaft Pinions, Motors, Gearboxes and Drive Flanges can be found in the GV3 Technical Guide.
- Standard Rack Driven Carriages are supplied with Double Row Bearings and Cap Seals. However, all variants, as available for Standard Carriages 22-25, can be supplied on request. Bespoke size Carriages can also be supplied. Please refer to the GV3 Technical Guide.
- The quoted Rack Drive Force is determined by Rack and Pinion size, gearbox bearings and gears, and the duty. Please refer to the GV3 Technical Guide.

HepcoMotion Gearboxes, AC Geared Motors and Drive Flanges can be used with Rack Driven Carriages 48, as well as with Rack Cut Single Edge Spacer Slides or separate Racks.

The high-duty yet lightweight Hepco Gearboxes with low backlash and low noise, make them particularly suitable for dynamic applications, whether driven by AC motor, stepper or servo. When sold separately, the input flange and shaft coupling of the Gearbox will be tailored to suit the customer's own motor. Gearboxes may be specified with an adjustable torque limiting clutch, if required.

The Drive Flange, which connects the Gearbox to the Carriage, incorporates a unique micro-adjustment facility for achieving correct engagement of Pinion with the Rack.

The AC Geared Motor can be combined with an AC Speed Controller to provide a complete drive control system. Motors are rated at 400/230V, protected to IP54, and finished in blue epoxy paint. Fitted disc brakes, alternative single and three phase windings, special finishes and enhanced IP protection are available on request.

Please see the GV3 Technical Guide for full details plus additional motor specifications available.

See Application Examples on 13 & 15

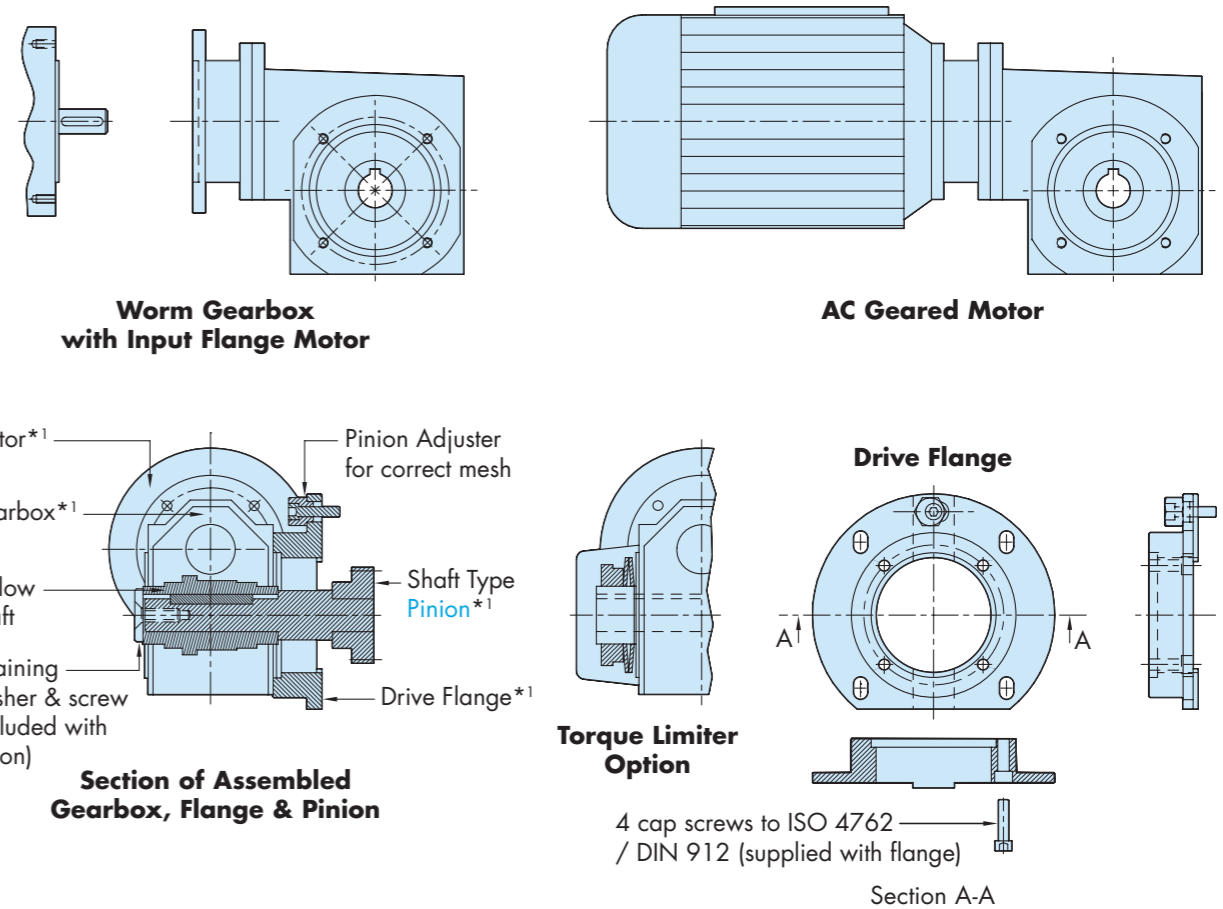

The AC Geared Motor and Worm Gearbox may be mounted onto a Rack Driven Carriage in any one of the eight configurations shown below. The terminal box may take one of four positions (A to D) and the cable exits also have four possible positions (1 to 4). Please use the diagram below as a guide to selection.

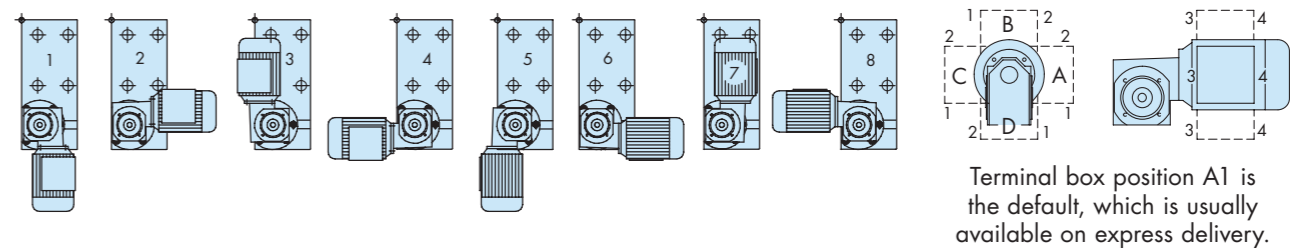

Terminal box position A1 is the default, which is usually available on express delivery.

Ordering Details

Please refer to the GV3 Technical Guide and contact Hepco to discuss requirements.



The load capacity and life of HepcoMotion 'V' Slide Systems*1 will be determined by several factors. The key issues are the size and type of **Bearing** and **Slide**, the presence or absence of lubrication and the magnitude and direction of loads. Other factors including operational speed, length of stroke and environmental conditions may also have an effect*2.

When calculating the system load and life, one of two approaches should be taken: if the system uses a conventional four-bearing **Carriage** (such as any of the Hepco Carriages), then this may be treated as a single item, and the load and life be determined as per the **Calculating Carriage Load Factor** section below; alternatively, each 'V' **Bearing** can be treated separately according to the method shown in the **Calculating 'V' Bearing Load Factor** section 51.

Calculating Carriage Load Factor*1,4

When calculating the life of a 'V' Slide System using a four-bearing Carriage, the loading on the system should be resolved into the direct load components, L1 and L2, and the moment load components M, Mv and Ms (see diagram on right). To calculate the system life, the load factor Lf should first be calculated using the equation below:

$$L_f = \frac{L_1}{L_{1(max)}} + \frac{L_2}{L_{2(max)}} + \frac{M_s}{M_{s(max)}} + \frac{M_v}{M_{v(max)}} + \frac{M}{M_{(max)}}$$

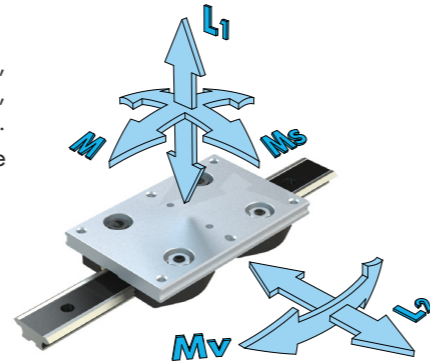

Lf should not exceed 1 for any combination of loads.

The maximum direct and moment load capacities are given in the following tables for **Standard** and **Slimline Carriages**. Capacities are included for both dry and lubricated conditions. This refers to the 'V' contact, since all **Bearings** are greased internally for life. Values are based on shock-free duty. Once Lf has been determined for the application, the life is calculated as shown 51.

Mv(max) and Ms(max) are determined by multiplying the figure shown in the tables below by the spacing of the **Bearings**, D, in metres (shown right).

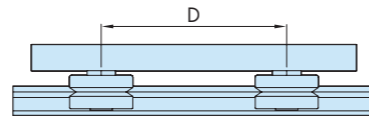

Carriage Part Number	Dry System, Twin & DR Type Bearing					Lubricated System, Twin Type Bearing					Lubricated System, DR Type Bearing				
	L1(max)	L2(max)	Ms(max)	Mv(max)	M(max)	L1(max)	L2(max)	Ms(max)	Mv(max)	M(max)	L1(max)	L2(max)	Ms(max)	Mv(max)	M(max)
	N	N	Nm	Nm	Nm	N	N	Nm	Nm	Nm	N	N	Nm	Nm	Nm
AU...12 13...	90	90	0.5	45xD	45xD	240	240	1.3	120xD	120xD	Not Available				
AU 20 18...	180	180	1.6	90xD	90xD	500	400	4.5	200xD	250xD	760	1200	7	600xD	380xD
AU 28 18...	180	180	2.3	90xD	90xD	500	400	6.5	200xD	250xD	760	1200	10	600xD	380xD
AU 25 25...	400	400	4.5	200xD	200xD	1280	1200	14	600xD	640xD	1600	3000	18	1500xD	800xD
AU 35 25...	400	400	6.5	200xD	200xD	1280	1200	21	600xD	640xD	1600	3000	26	1500xD	800xD
AU 50 25...	400	400	9.5	200xD	200xD	1280	1200	30	600xD	640xD	1600	3000	38	1500xD	800xD
AU 44 34...	800	800	16	400xD	400xD	3200	2800	65	1400xD	1600xD	3600	6000	73	3000xD	1800xD
AU 60 34...	800	800	22	400xD	400xD	3200	2800	90	1400xD	1600xD	3600	6000	100	3000xD	1800xD
AU 76 34...	800	800	29	400xD	400xD	3200	2800	115	1400xD	1600xD	3600	6000	130	3000xD	1800xD
AU 76 54...	1800	1800	64	900xD	900xD	7200	6400	250	3200xD	3600xD	10000	10000	360	5000xD	5000xD
AU 120 54...	1800	1800	100	900xD	900xD	7200	6400	410	3200xD	3600xD	10000	10000	580	5000xD	5000xD

Carriage Part Number	Dry System, Slimline Type Bearing					Lubricated System, Slimline Type Bearing				
	L1(max)	L2(max)	Ms(max)	Mv(max)	M(max)	L1(max)	L2(max)	Ms(max)	Mv(max)	M(max)
	N	N	Nm	Nm	Nm	N	N	Nm	Nm	Nm
AU 20 195...	180	180	1.6	90xD	90xD	400	480	3.5	240xD	200xD
AU 28 195...	180	180	2.3	90xD	90xD	400	480	5	240xD	200xD
AU 25 265...	400	400	4.5	200xD	200xD	940	1150	10.5	575xD	470xD
AU 35 265...	400	400	6.5	200xD	200xD	940	1150	15	575xD	470xD
AU 50 265...	400	400	9.5	200xD	200xD	940	1150	22	575xD	470xD
AU 44 360...	800	800	16	400xD	400xD	2000	2400	40	1200xD	1000xD
AU 60 360...	800	800	22	400xD	400xD	2000	2400	55	1200xD	1000xD
AU 76 360...	800	800	29	400xD	400xD	2000	2400	70	1200xD	1000xD
AU 76 580...	1800	1800	64	900xD	900xD	4240	5200	150	2600xD	2120xD
AU 120 580...	1800	1800	100	900xD	900xD	4240	5200	240	2600xD	2120xD

Calculating 'V' Bearing Load Factor*1,3,4

Many systems do not use a standard four-bearing **Carriage**. In such cases it is necessary to use conventional statics calculations to determine the loading on each **Bearing** in the system, by resolving loads into axial (LA) and radial (LR) components.

The maximum LA and LR load capacities for all types of Hepco 'V' **Bearing** are given in the table below. Capacities are included for both 'dry' and 'lubricated' conditions. This refers to the 'V' contact, since all **Bearings** are greased internally for life. Values are based on shock-free duty.

The load capacities stated in the table below assume that **Bearings** are used with **Slides** equal to or larger than the preferred **Slide** selection for that **Bearing** size. For details of the preferred sizes, see tables 34-37. For loading of **Bearings** with smaller **Slides**, please contact Hepco.

To calculate the system life, the load factor Lf should first be calculated using the equation below: Lf should not exceed 1 for any combination of loads.

$$L_f = \frac{L_A}{L_{A(max)}} + \frac{L_R}{L_{R(max)}}$$

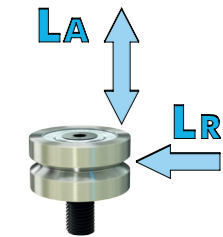

Twin Type Bearing		Double Row (DR) Type Bearing				Slimline Type Bearing								
Part Number	Dry System	Lubricated		Part Number	Dry System	Lubricated		Part Number	Dry System	Lubricated				
	LA(max)	LR(max)	LA(max)		LR(max)	LA(max)	LR(max)		LA(max)	LR(max)				
...J13...	22.5	45	60	120	-	-	-	-	-	-	-			
...J18...	45	90	125	200	...J18 DR...	45	90	190	600	...J195...	45	90	100	240
...J25...	100	200	320	600	...J25 DR...	100	200	400	1500	...J265...	100	200	235	575
...J34...	200	400	800	1400	...J34 DR...	200	400	900	3000	...J360...	200	400	500	1200
...J54...	450	900	1800	3200	...J54 DR...	450	900	2500	5000	...J580...	450	900	1060	2600

Once Lf has been determined for each **Bearing**, the life can be calculated as follows:

Calculating Carriage or Individual 'V' Bearing Life*2,3,5,6

Life in km can be calculated using one of the two equations below. In these equations, the Basic Life is taken from the table below in respect of the **Bearing** type and the lubrication condition applicable.

Dry System

$$\text{Life (km)} = \frac{\text{Basic Life}}{(0.03 + 0.97L_f)^2}$$

Lubricated System

$$\text{Life (km)} = \frac{\text{Basic Life}}{(0.03 + 0.97L_f)^3}$$

Twin Type Bearing		Double Row (DR) Type Bearing				Slimline Type Bearing	
Part Number	Dry System	Lubricated		Part Number	Dry System	Lubricated	
...J13...	40	50		-	-	-	
...J18...	50	100		...J18 DR...	50	100	
...J25...	70	50		...J25 DR...	70	70	
...J34...	100	100		...J34 DR...	100	250	
...J54...	150	250		...J54 DR...	150	500	
...J195...	50	100		...J195...	50	100	
...J265...	70	50		...J265...	70	50	
...J360...	100	100		...J360...	100	250	
...J580...	150	250		...J580...	150	200	

Notes:

- The maximum values of LA and LR, and the magnitudes of the system Basic Life for each **Bearing** type relate to the performance of complete systems. Tests have shown these figures to be more reliable than working from the theoretical static and dynamic load capacities (C and Co) of the bearings. Values of C and Co have been included in tabulated data on the relevant **Bearing** pages as a means of comparison with other systems.
- The calculations within this section assume that the linear stroke involves a number of complete **Bearing** revolutions. If the stroke of any application is less than five times the **Bearing** outside diameter, calculate the distance travelled as if it moves five **Bearing** diameters per stroke. Systems operating at speeds in excess of 8 m/s may require additional calculation. Please contact Hepco for assistance.
- For the purposes of the Load/Life Calculations on this page, the axial load LA is the load in the axial direction that the **Bearing** can accept from a 'V' **Slide** engaged in its outer ring. Since the line of force is some distance removed from the axis of the **Bearing**, this value is much less than the theoretical axial load capacity, quoted on the relevant **Bearing** page.
- In the above calculations, the term 'lubricated' refers to the contact between the **Slide** and **Bearing** 'V's. This lubrication may best be achieved using Hepco **Cap Seals**, **Cap Wipers**, **Lubricators** or **Bleed Lubrication** facility. However, other methods that ensure the presence of suitable lubrication are acceptable.
- When a system consists of more than four **Bearings** per **Carriage** (see Application Examples 11 & 17), it cannot always be guaranteed that the load will share equally between all **Bearings**. In such cases, it is recommended that Controlled Height **Bearings** are specified (where available) and that the system is de-rated to allow for the life of the most heavily laden **Bearing**.
- For some sizes of DR **Bearing**, the actual life for applications with mainly L2/radial loads may be higher than the calculations indicate. This is because the calculations are simplified for easy use. Please contact Hepco for details in instances where a higher system life is required.

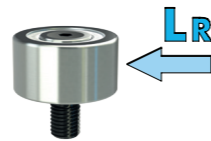
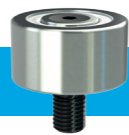

Systems incorporating **Track Rollers** running on **Flat Tracks** or the flat faces of **Single Edge Spacer Slides** will require a different calculation to determine the load and life.

Track Rollers only have a radial load capacity stated, as they are not usually loaded axially. Their pure rolling contact with the Track means that they do not need to be de-rated for use in unlubricated applications (although it is recommended that the Tracks and Rollers be lightly oiled for best performance).

Calculating the System Load Factor*1

To calculate the Roller life, the load factor L_f should first be calculated using the equation below: L_f should not exceed 1.

$$L_f = \frac{L_R}{L_{R(max)}}$$

The maximum radial load capacity $L_{R(max)}$ for the Hepco range of **Track Rollers** is stated below:

Max Working Load Capacity*1			
Narrow Roller Type	$L_{R(max)}$	Wide Roller Type	$L_{R(max)}$
	N		N
LRN 18...	400	...R 18...	600
LRN 25...	1000	...R 25...	1600
LRN 34...	2000	...R 34...	3200
LRN 54...	5000	...R 54...	8000

Calculating Track Roller Life*2

With L_f determined for each Roller, the life in km can be calculated using the equation below. Please note that the 'Basic Life' for all Track Rollers is 1000 km, so a lookup table is not required.

$$\text{Life (km)} = \frac{1000}{L_f^3}$$

Load Capacity of the Track Roller Running Surface

In a system using a Track Roller running on a flat surface, it may be necessary to reduce the maximum loads applied if the track is not sufficiently hard. All Hepco **Flat Tracks** are hardened, and these can be used in conjunction with Hepco Track Rollers up to the maximum load capacities stated in the table above. Even higher loads up to the static load capacity, C_o , of the bearings (see Track Roller 43-45) are possible without damage.

For softer running faces, such as the rear face of the Hepco **Single Edge Spacer Slides**, the maximum **Track Roller** loads are reduced as stated in the table below:

Track Roller Maximum Load Capacities (N)				
Description of Track Roller Running Surface	Used with Track Roller type			
	LRN18...&...R18...	LRN25...&...R25...	LRN34...&...R34...	LRN54...&...R54...
Hepco Flat Tracks FT...	The load is limited by the $L_{R(max)}$ figure for the Track Roller			
Rear of Hepco Single Edge Slide	310	510	680	1600

It should be noted that while a softer running face will limit the maximum load that can be exerted by a **Track Roller**, the life of the Track Roller at any given load is not affected.

Notes:

- The values of L_R , and the system Basic Life for each **Track Roller** relate to the performance of complete systems. Tests have proven these figures to be more reliable than working from the theoretical static and dynamic load capacities (C and C_o) of the bearing. Values of C and C_o have been included in tabulated data on the relevant Track Roller pages as a means of comparison with other systems.
- The calculations within this section assume that the linear stroke involves a number of complete **Track Roller** revolutions. If the stroke of any application is less than five times the Track Roller outside diameter, then please calculate the distance travelled as if it moves five Track Roller diameters per stroke. Systems operating at speeds in excess of 8 m/s may require additional calculation. Please contact Hepco for assistance.

'V' Slides

Material and finish: High carbon bearing steel AISI 52100, hardened on 'V' faces to typically 58-62 Rockwell 'C' scale. Those areas which are ground have N5 surface finish. Other areas have a chemical black finish.

Flat Tracks

Material and finish: Carbon or alloy steel, hardened on all faces to typically 58-62 Rockwell 'C' scale. Areas which are ground have N5 surface finish. Other areas have a chemical black finish.

Bearings & Track Rollers

Raceways, balls & taper-rollers: Carbon-chromium bearing steel AISI 52100, hardened and tempered.
 Shields: Steel with bright zinc plated finish.
 Seals: Nitrile rubber
 Cage: Plastic
 Axles: High tensile steel with tensile strength = 695 N/mm². Chemical black finish.
 BH...'E' base plate: Steel with chemical black finish.
 Temperature range: -20°C to +120°C

Carriage Plates, Slide Beams, End Stops, Shock Absorber Fixing Blocks & Flange Clamps

Material: High strength aluminium alloy
 Finish: Clear anodised to 15µm thickness.

Carriage Plate & Slide Counterbore Plugs

Material: Plastic

Cap Seals

Material: Body: Thermoplastic elastomer
 Inserts: Impact resistant plastic
 Wipers: Felt
 Temperature range: -20°C to +60°C

Cap Wipers & Lubricators

Material: Impact resistant plastic with felt wiper.
 Temperature range: -20°C to +60°C

Racks

Material and finish: Carbon steel with chemical black finish

Pinions

Material and finish (< Mod 1): EN40B steel. Unground. Teeth hardened. ISO 1328-1 accuracy grade 10.
 Material and finish (≥ Mod 1): Standard version: Case hardened EN36 steel. Teeth and bore ground to N5 finish. ISO 1328-1 accuracy grade 6.
 Stainless steel version: Hardened 420 series stainless steel. Ground on teeth and all main surfaces to N5 finish. ISO 1328-1 accuracy grade 6.

Frictional Resistance for 'V' Slide Systems

Coefficient of friction (without **Cap Seals**, **Cap Wipers** or **Lubricators**) = 0.02
 Cap Seals and Lubricators add friction as follows:
 Four Cap Seals or Wipers per Carriage CS18 or CW195 = 4 N, CS25 or CW265 = 7 N, CS34 or CW360 = 15 N, CS54 or CW580 = 28 N
 Two Lubricators per Carriage LB12 = 1 N, LB20 & LB195 = 1.5 N, LB25 & LB265 = 2.5 N, LB44 & LB360 = 3 N, LB54 & LB580 = 4 N

External Lubrication

Cap Seals and **Cap Wipers** should be lubricated with grease NLGI consistency No. 2.
Lubricators should be oiled using 68 cSt viscosity or similar oil. Food compatible lubricants can also be used.

Maximum Linear Speeds for 'V' Slides & Bearings and Flat Tracks & Rollers

Unlubricated 'V' Slides = 2 m/s } Higher speeds are possible. Speed depends upon stroke, duty and environmental conditions.
 Lubricated 'V' Slides and all Flat Track applications = 8 m/s }

Material specifications may change for reasons of technical advantage or availability.

CATALOGUE No. GV3 12 UK © 2018 Hepco Slide Systems Ltd.

Reproduction in whole or part without prior authorisation from Hepco is prohibited. Although every effort has been made to ensure the accuracy of the information in this catalogue, Hepco cannot accept liability for any omissions or errors. Hepco reserves the right to make alterations to the product resulting from technical developments. Many Hepco products are protected by: Patents, Copyright, Design Right or Registered Design. Infringement is strictly prohibited and may be challenged in law. The Customer's attention is drawn to the following clause in Hepco's conditions of sale: 'It shall be the Customer's sole responsibility to ensure that goods supplied by Hepco will be suitable or fit for any particular application or purpose of the Customer, whether or not such application or purpose is known to Hepco. The Customer will be solely responsible for any errors in, or omissions from, any specifications or information the Customer provides. Hepco will not be obliged to verify whether any such specifications or information are correct or sufficient for any application or purpose.' Hepco's full conditions of sale are available on request and will apply to all quotations and contracts for the supply of items detailed in this catalogue. HepcoMotion is the trading name of Hepco Slide Systems Ltd.



HepcoMotion®

ADVANCED LINEAR SOLUTIONS

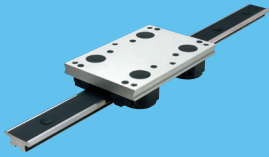

GV3

Linear Guidance and Transmission System

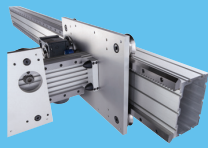

HDS2

Heavy Duty Slide System

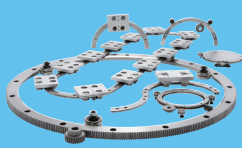

PRT2

Ring Slides and Track System



HDRT

Heavy Duty Ring Slides and Track System

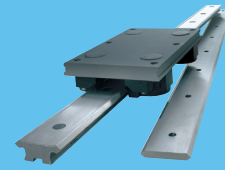

SL2

Stainless Steel Based Slide System

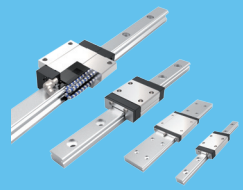

HLG

Hepco Ball Guides

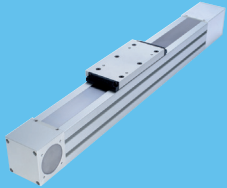

SBD

Sealed Belt Drive

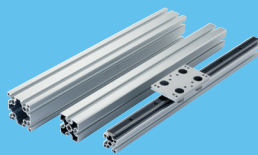

MCS

Aluminium Frame and Machine Construction System

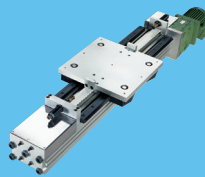

HDLS

Heavy Duty Driven Linear System

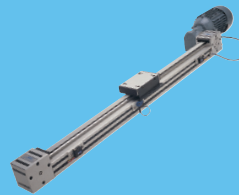

DLS

Linear Transmission and Positioning System

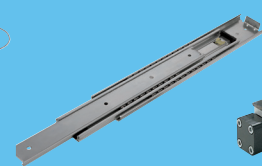

HTS

Telescopic Ball Bearing Slides



HPS

Powerslide-2 Guided Rodless Cylinder

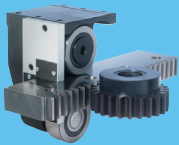

MHD

Heavy Duty Track Roller Guidance System

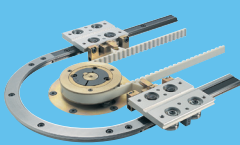

DTS

Driven Track System

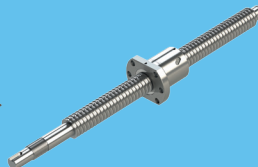

Hepco Ball Screws



Simple Select®
Vee Slide Linear Guidance Systems

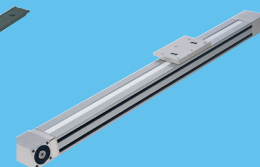

PDU2

Profile Driven Unit

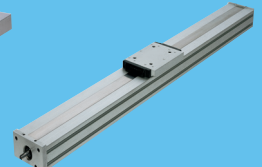

PSD120

Profile Screw Driven Unit



Shaft

Precision Steel and Aluminium Shaft

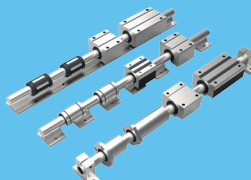

Ball Bushings

Linear Bearing System

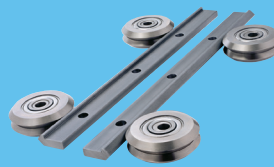

DUALVEE®

Single Edge Slide System

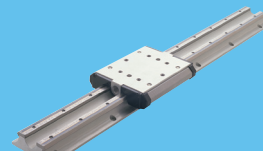

LoPro®

Aluminium Based Slide System



UtiliTrak®

Lightweight U Channel Guideway

For further information on HepcoMotion® products and details of worldwide representation, please visit:

HepcoMotion.com

HepcoMotion Group Headquarters

www.hepcotion.com

Lower Moor Business Park
Tiverton Way, Tiverton
EX16 6TG
England

Tel: +44 (0)1884 257000
Email: sales@hepcotion.com

HepcoMotion Germany

(Also covering Austria & German-speaking Switzerland)

www.hepcotion.com/de

Tel: +49 (0) 9128 92710
Email: info.de@hepcotion.com

HepcoMotion France

(Also covering French-speaking Switzerland)

www.hepcotion.com/fr

Tel: +33 (0) 1 34 64 30 44
Email: info.fr@hepcotion.com

HepcoMotion Benelux

(Covering Belgium, Luxembourg & Netherlands)

www.hepcotion.com/nl

Tel: +31 (0) 492 551290
Email: info.nl@hepcotion.com

HepcoMotion Spain

www.hepcotion.com/es

Tel: +34 93 205 84 47
Email: info.es@hepcotion.com

HepcoMotion South Korea

www.hepcotion.co.kr

Tel: +82 (0) 31 352 7783
Email: hepcokr@chol.com

HepcoMotion China

www.hepcotion.com.cn

Tel: +86 21 5648 9055
Email: sales.china@hepcotion.com



Certification Number 14479
ISO 9001